

Z323 ST1000+ and Z324 ST2000+ Autopilot Service Procedures

CE MARKING OF EQUIPMENT/REPLACEMENT PARTS**WARNING**

If the Autohelm equipment under repair, test, calibration, installation or setting to work carries the European CE mark, only parts and components supplied or approved for such use by Autohelm should be used in order to maintain compliance with the relevant CE requirements.

Incorporation, use or attachment, by any means, of parts or components not supplied for or not approved for such use by Autohelm or, if supplied or approved for use by Autohelm, not properly fitted in accordance with instructions published, provided or recommended by Autohelm, may cause the equipment to malfunction and, in particular, to become unsafe or to no longer meet the relevant CE requirements. In these circumstances, Raytheon Marine Europe Ltd excludes liability to the fullest extent permissible in law for any loss or damage including any liability for its contribution to such loss or damage by its negligent acts or omissions .

Contents

1. Description	5
2. Operation	5
3. Disassembly and Assembly	6
3.1 Upper Case Removal	6
3.2 PCB Removal	6
3.3 Display Assembly	8
3.4 Drive Module Removal	9
3.5 Drive Motor Replacement	9
3.6 Fluxgate Compass Removal and Installation	10
3.7 Drive Module Assembly	10
3.8 PCB Installation	11
3.9 Upper Case Refitting	11
4. Special Functions	12
4.1 Changing the Operating Sense	12
4.2 Display Test	12
4.3 Autopilot Type Selection	12
4.4 Display of Software Code	12
4.5 Calibration Lockout	13
5. Functional Test	14
5.1 Overall Test	14
5.2 SeaTalk and NMEA Tests	15
5.3 Keypad	15
5.4 Display	15
5.5 Drive Assembly	16
5.6 Fluxgate Compass Assembly	16
6. Block Diagram and Signal Tables	17
Main Cable Connectors	17
Fluxgate Compass Connector (SKT1)	17
7. Software History	19
8. Spares numbers	19

9. Circuit Diagram and PCB Layout	20
10. PCB Components List	22

Contents

Figure 1. Exploded View	7
Figure 2. Display Assembly	8
Figure 3. Gearbox Assembly	9
Figure 4. Cable Routing.....	10
Figure 5. Spade Terminal Connections to PCB	11
Figure 6. Test Equipment.....	14
Figure 7. Fluxgate Electrical Connections	16
Figure 8. Block Diagram	18
Figure 9. PCB Layout	20
Figure 10. PCB Layout	21

1. Description

This section of the Service Manual details the Servicing Procedures for the Autohelm ST1000+ Tiller Autopilot, Catalogue Number Z323 and Autohelm ST2000+ Tiller Autopilot, Catalogue Number Z324.

2. Operation

Full details of operation and calibration are given in the User Handbook, Publication Number 81130-1

3. Disassembly and Assembly

Before dismantling the autopilot, check the operating sense (port/starboard), if the PCB condition allows. All new PCBs are factory set to starboard operating sense. A replacement PCB in a unit set up for port operation must be set to port operation.

The autopilot may be calibrated to suit a particular vessel. Note the calibration settings and set up the new PCB if required.

If the spares PCB contains software of a higher issue than the PCB it replaces, the relevant Operating Supplement(s) must be included when the equipment is returned to the customer.

Replacement PCBs are set up as ST1000+.

Component identification numbers refer to Figure 1, Exploded View, unless a detail figure is identified at the start of a section.

3.1 Upper Case Removal

1. Ensure the drive unit is fully retracted
2. Remove the case securing screws (10, 8 off)
3. Lift off the upper case (1)

Do not run the actuator assembly with the upper case removed and the PCB in place. There is insufficient clearance between the guide bridge and the PCB and damage to PCB components may result.

If it is required to run the actuator the PCB should be unscrewed and lifted slightly.

3.2 PCB Removal

All work on the PCB should be carried out taking normal static precautions.

1. Remove the upper case (1)
2. Remove the screws (19, 3 off) securing the PCB
3. Lift the PCB off its support pillars and disconnect the Fluxgate flexible circuit (16) from connector SK1. Disconnect the power, data, screen, NMEA +, NMEA- and motor spade connectors (22, 23, 24) from the PCB.

Replacement PCBs are supplied without an LCD. If changing the PCB refer to section 3.3 for instructions to remove and transfer the display assembly to a replacement PCB.

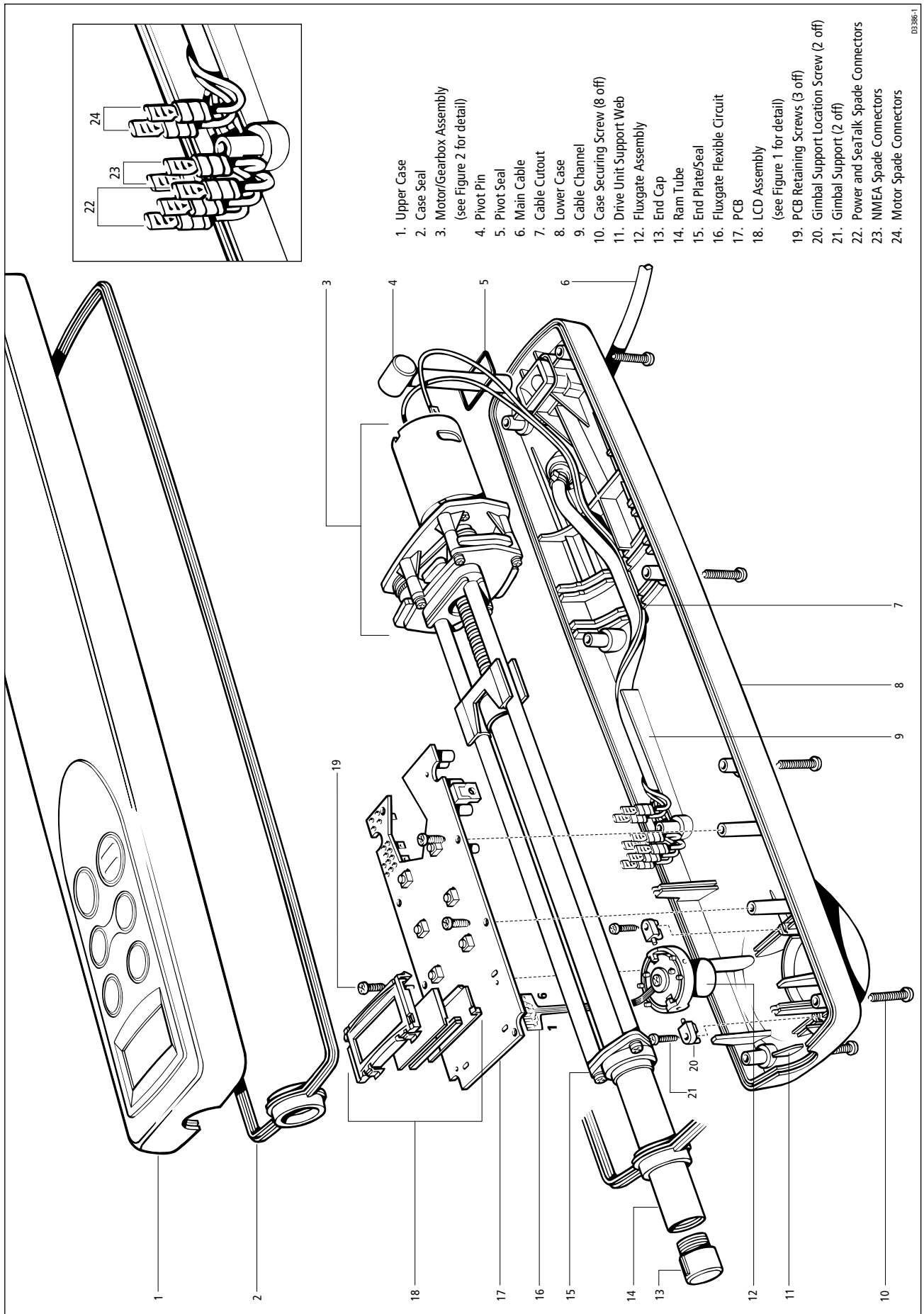

1. Upper Case
2. Case Seal
3. Motor/Gearbox Assembly
(see Figure 2 for detail)
4. Pivot Pin
5. Pivot Seal
6. Main Cable
7. Cable Cutout
8. Lower Case
9. Cable Channel
10. Case Securing Screw (8 off)
11. Drive Unit Support Web
12. Fluxgate Assembly
13. End Cap
14. Ram Tube
15. End Plate/Seal
16. Fluxgate Flexible Circuit
17. PCB
18. LCD Assembly
(see Figure 1 for detail)
19. PCB Retaining Screws (3 off)
20. Gimbal Support Location Screw (2 off)
21. Gimbal Support (2 off)
22. Power and Seatalk Spade Connectors
23. NMEA Spade Connectors
24. Motor Spade Connectors

D3386-1

Figure 1. Exploded View

3.3 Display Assembly

Refer to Figure 2.

The display assembly is a snap fit which is retained on the PCB by four moulded lugs (2). The backlight diffuser (6) clips into the display bezel (1) and retains the LCD and its elastomer connector (3).

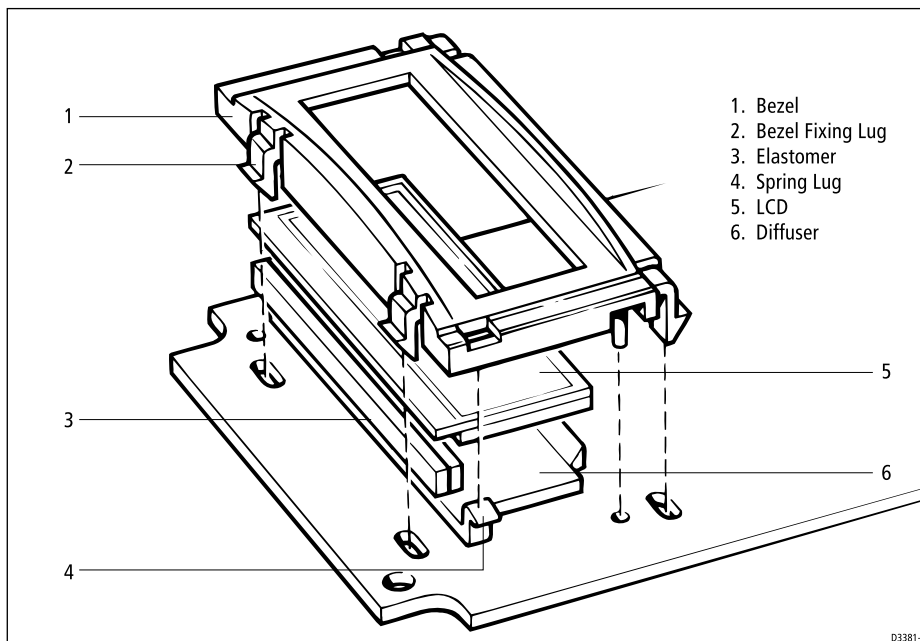

Figure 2. Display Assembly

The display is back lit via the diffuser by two green LEDs which are mounted directly on the PCB.

Removal

1. Unclip the bezel lugs (2) from the PCB (Upper pair first then lower pair)
2. Ease the complete display assembly from the board.

Installation

If fitting a new LCD the marked protective film must be removed.

1. Place the LCD (5) into the bezel (1) (note orientation)
2. Place the elastomer connector (3) on top of the LCD connection strip (note orientation)
3. Insert the diffuser (6) into the bezel so that the two spring lugs (4) locate into the display bezel
4. Press the display assembly on to the PCB ensuring all four bezel lugs (2) locate correctly.

3.4 Drive Module Removal

1. Remove the PCB
2. Lift out the drive assembly and ease the ram tube (14) from the case seal (2).

3.5 Drive Motor Replacement

Refer to Figure 3.

1. Remove the drive module
2. Remove the gearbox securing screws (10, 4 off)
3. Separate the support plates (7, 2 off)
4. Remove the motor securing screws (8, 2 off) from the rear plate.

The motor can now be lifted away and a replacement fitted.

Replacement is a reversal of the removal procedure. After securing the gearbox ensure both belts (9, 2 off) are fitted correctly by hand turning the leadscrew drive pulley (4) and observing correct belt tracking.

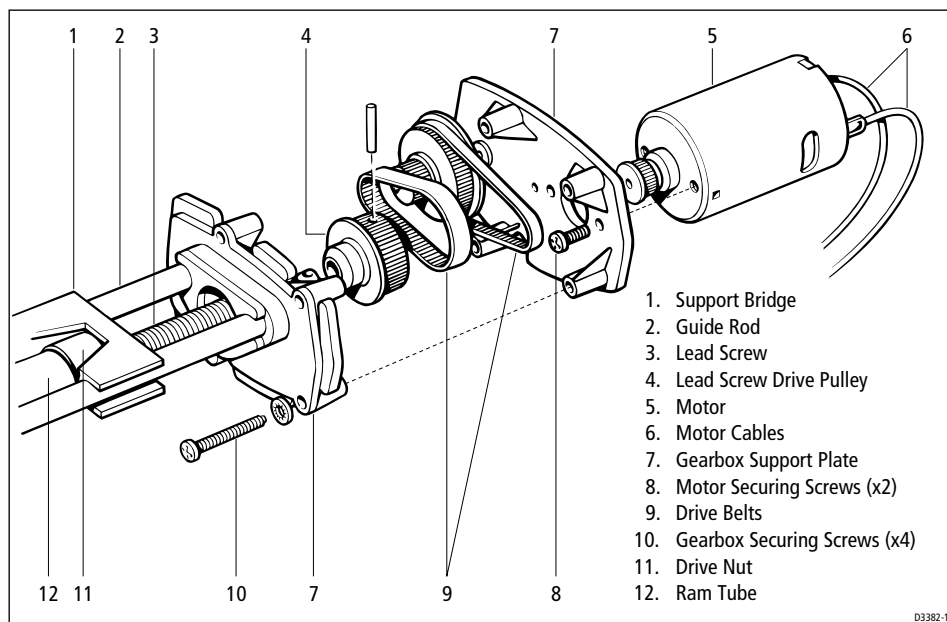

Figure 3. Gearbox Assembly

3.6 Fluxgate Compass Removal and Installation

1. Remove the drive module
2. Remove the gimbal supports (21, 2 off)
3. Lift out the fluxgate assembly (12).

Replacement is a reversal of the removal procedure. Note the orientation of the flexible circuit tail (16).

The tail of the fluxgate can be easily damaged and care should be taken not to fold or bend it sharply.

3.7 Drive Module Assembly

1. Locate the main cable (6) and red and black motor leads in the channel (9) at the side of the lower case (8)
2. Enter the ram tube (14) into the case seal (2).
3. Lay the drive module into the lower case making sure the cables pass through the cutout (7) in the gearbox support plates as shown in Figure 3
4. Lay the case seal (2) in the outer groove around the perimeter of the lower case.

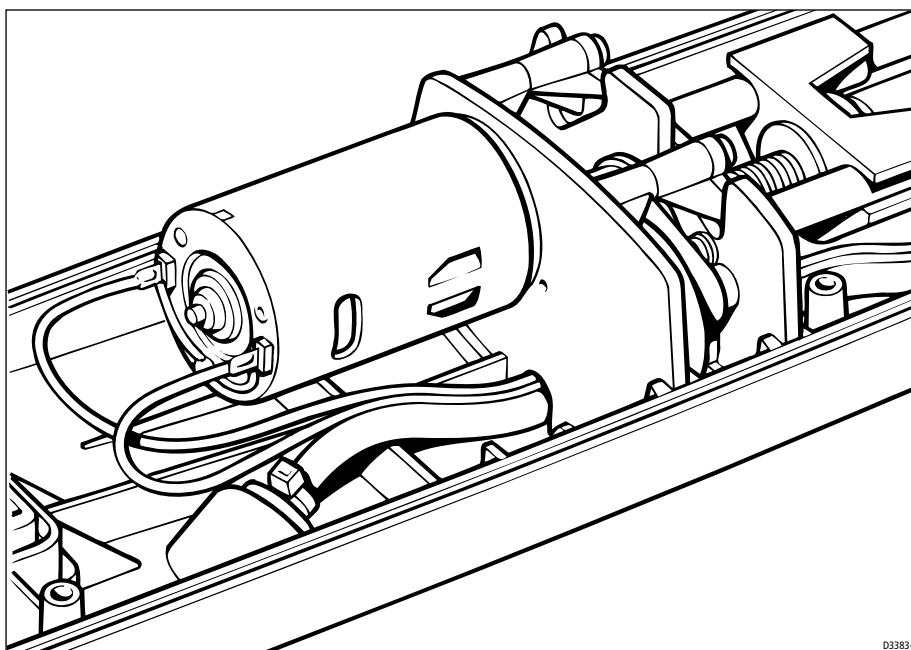

Figure 4. Cable Routing

3.8 PCB Installation

Before refitting the PCB check that the drive assembly is fully retracted. Failure to do this results in damage to the PCB at installation.

Check the PCB to ensure that the four FET drive transistors are mounted vertically and not bent over at an angle.

1. Remove the display assembly from the old PCB and fit to the new board (see section 3.3)
2. Connect the main cable and motor cable wires to the PCB tags. Ensure correct connection. Refer to Figure 4.

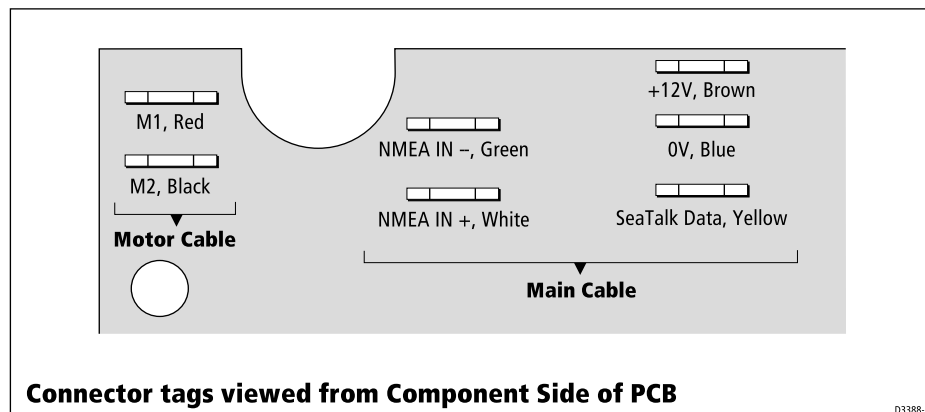

Figure 5. Spade Terminal Connections to PCB

3. Connect the fluxgate flexible circuit tail (16) into PCB socket SKT1. (Ensure correct orientation. Refer to Figure 8)
4. Lower the PCB onto the location pillars
5. Lock in place with the securing screws (19, 3 off)
6. Power up the unit and confirm display operation by momentarily pressing the -1 and +10 degree keys. The display should count up from 0 to 9 on all four characters, then display all other annotations. Observe the display and confirm all segments are switching on.

3.9 Upper Case Refitting

1. Clean the LCD and the window in the upper moulding with a lint free anti static wipe
2. Ensure the case seal is seated correctly in the outer groove around the perimeter of the lower case
3. Ensure the O ring seal (5) is located around the pivot pin (4)
4. Lower the upper case onto the assembly and locate with the securing screws (10, 8 off). Do not over tighten (8 in lbs max.).

4. Special Functions

4.1 Changing the Operating Sense

All units are supplied from the factory set up as Starboard.

The operating sense of the autopilot can be reversed by pressing the +1° and -1° course change keys together for 5 seconds

The unit should beep for 10 seconds to confirm change over and the display should show the new setting, either Port or Starboard.

4.2 Display Test

A special display test feature in the ST1000/200+ software checks that the display assembly is fitted correctly after changing the PCB. Display test is switched on by momentarily pressing the -1° and +10° keys together.

The display should scroll all four characters through from 0 to 9 and then display each annotation. This sequence continues until the Standby or Auto key is pressed or the unit is powered down.

4.3 Autopilot Type Selection

The ST1000+ and ST2000+ autopilots use the same PCB (Q218), but gears in the ST1000+ and ST2000+ drive modules are different, so each pilot runs a different program. Both sets of software are contained within the same chip.

To select the correct program:

1. Press the -10° and +1° keys until the display shows the pilot type number, 2000 or 1000 (approx. 5 seconds)
2. Press the -10° and +1° keys again until the display flashes the pilot type number (approx. 5 seconds)
3. Select the correct pilot type using the +1° and -1° keys
4. Save the setting by pressing the -10° and +1° keys until the normal Standby display appears (approx. 2 seconds)

Changing Autopilot type clears all calibration setting/compass linearisation and returns the unit to factory setting.

4.4 Display of Software Code

The software code of the pilot can be displayed by switching the pilot to standby mode and pressing the Standby key until the display shows P followed by a number (approx. 10 seconds).

The number indicates the version of software fitted, for example, P 0 6 indicates Version 6 software.

4.5 Calibration Lockout

Access to the compass linearisation and calibration functions on the ST1000+/2000+ autopilots can be prevented. This can be a useful feature, for example, to charter boat operators who spend a lot of time tuning the pilot to the boat, only to find a customer alters the settings at a later date.

Any attempt to linearise the compass or enter calibration when the lockout function is enabled results in the display showing Cal Off. The user cannot then change any settings.

To disable calibration:

1. Press and hold the -1° and Standby keys for 10 seconds until the display shows CAL ON
2. Toggle calibration access between ON and OFF using the -1° and $+1^\circ$ keys
3. Store the selected setting by pressing the -1° and Standby keys for 10 seconds.

5. Functional Test

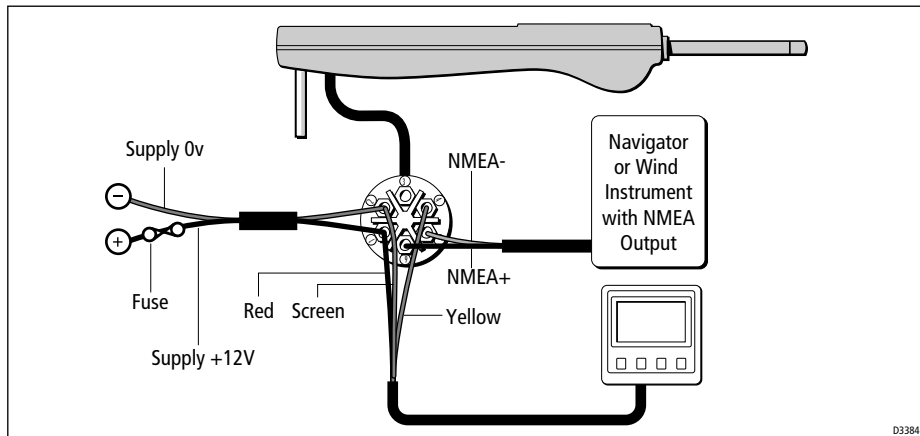
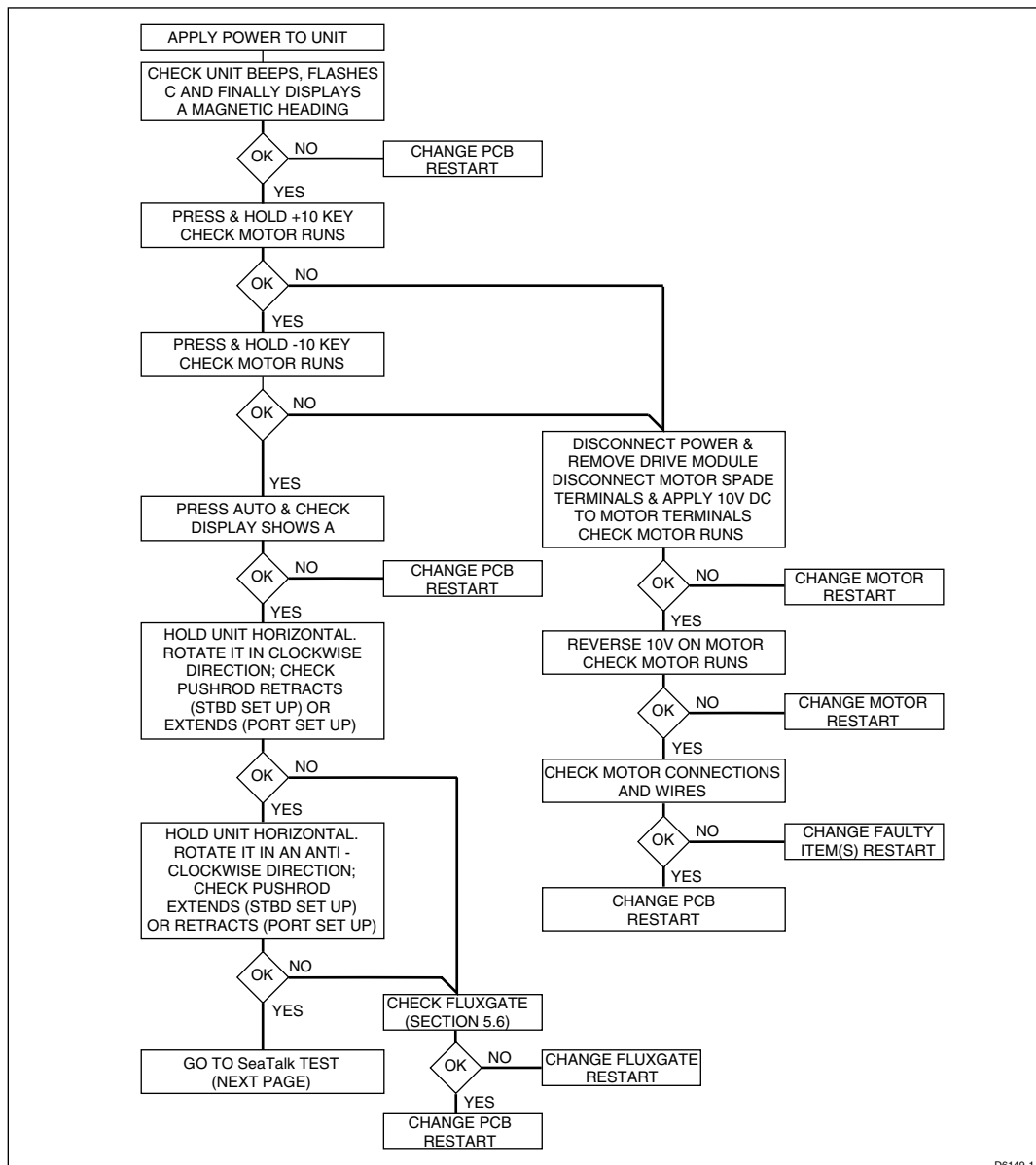
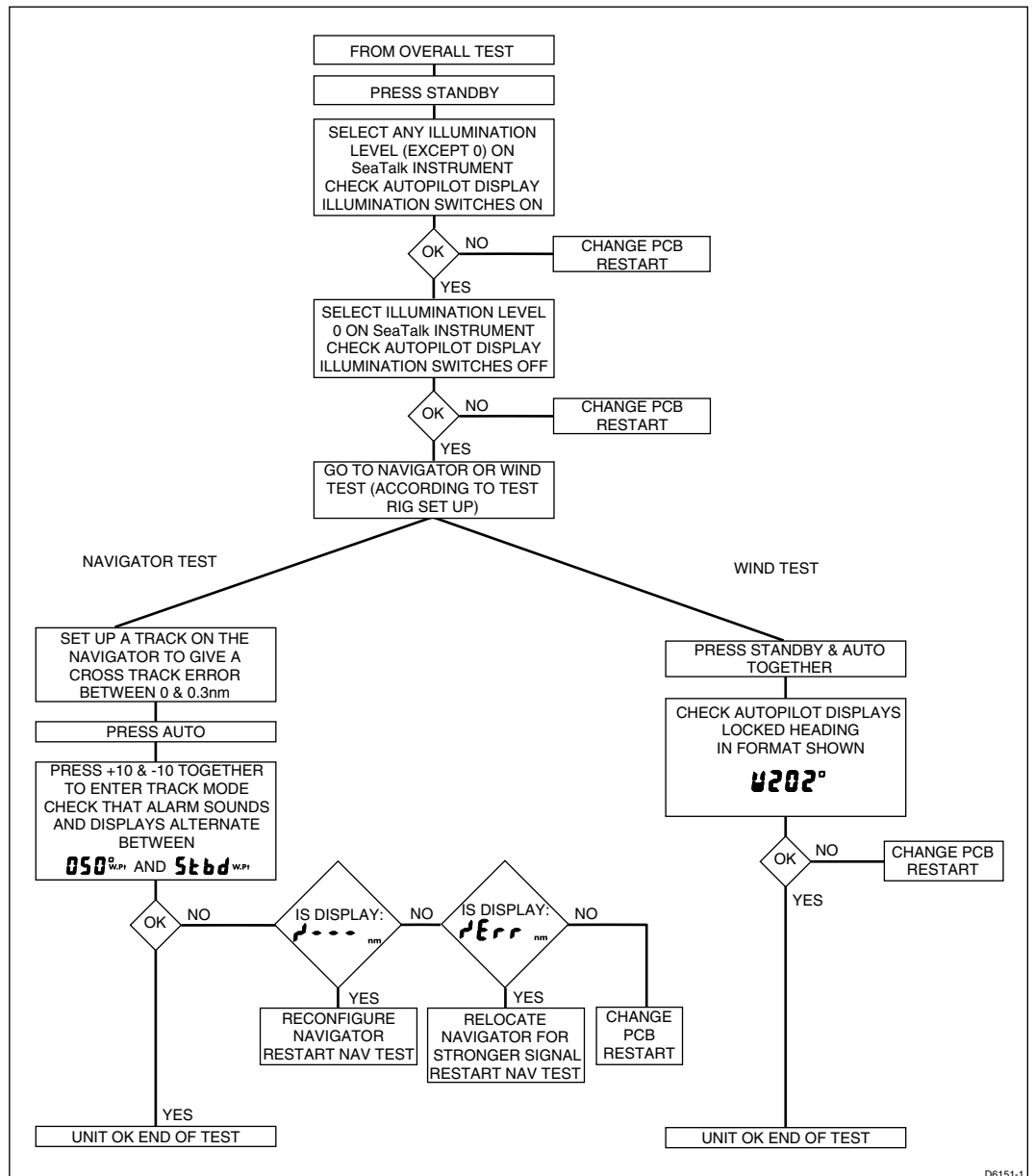

Figure 6. Test Equipment

5.1 Overall Test



5.2 SeaTalk and NMEA Tests



5.3 Keypad

The keypad can be checked by pressing each key in turn. All keys should respond with a tactile metallic click and an audible beep. If this is not the case the PCB should be replaced.

5.4 Display

To check operation of the display, refer to section 4.2.

5.5 Drive Assembly

Remove the drive assembly from the lower case. Connect a 10V dc supply to the motor terminals and measure the running current of the drive unit with the drive running freely and not against either end stop.

<2A - Drive Healthy >2A - Drive Faulty

5.6 Fluxgate Compass Assembly

Remove the fluxgate assembly

The compass can be checked with a DVM.

Connect Meter across Pins	Resistance
1 and 2	<10 ohms
3 and 5	<5 ohms
3 and 4	<5 ohms
1 and 3	Open Circuit

830014

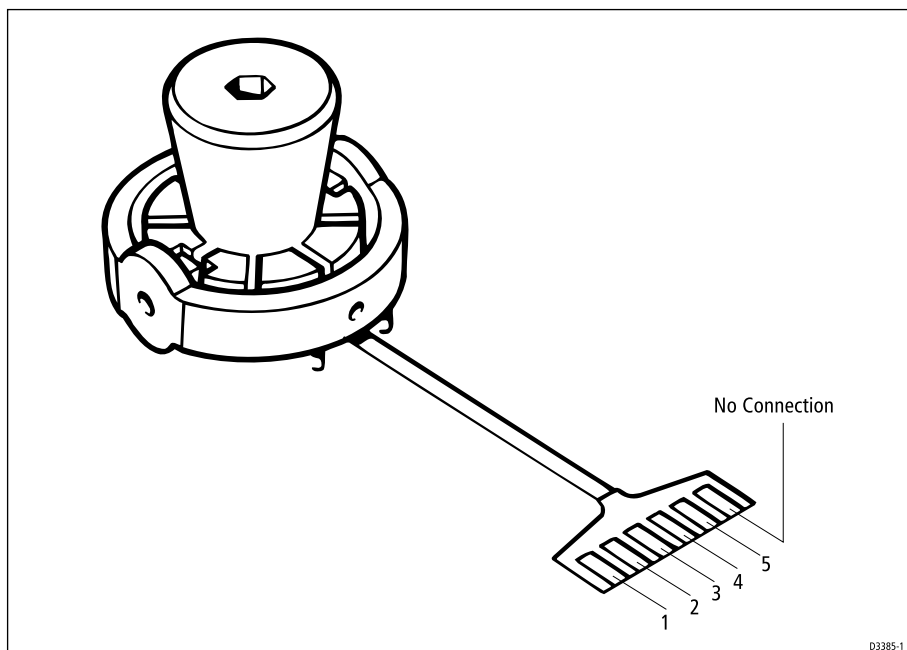

03385-1

Figure 7. Fluxgate Electrical Connections

6. Block Diagram and Signal Tables

Main Cable Connectors

Signal	
+12VIN	Nominal 12V dc
0VIN	0V
SeaTalk	Intermittent 12V (nominal) pulse streams
NMEAIN+	Intermittent 12V (nominal) pulse streams
NMEAIN-	Intermittent 12V (nominal) pulse streams

83130r10

Fluxgate Compass Connector (SKT1)

Pin No.	Signal	
1		Not Used
2	VRESET	Nominal 2.5V DC
3	F/GB	Compass Input (2) Nominal 2.5V DC
4	F/GA	Compass Input (2) Nominal 2.5V DC
5	F/G DRIVE	AC, 17 cycles at 7.9 KHz, driven twice every 1/16 second
6	0V	0V DC

83130r11

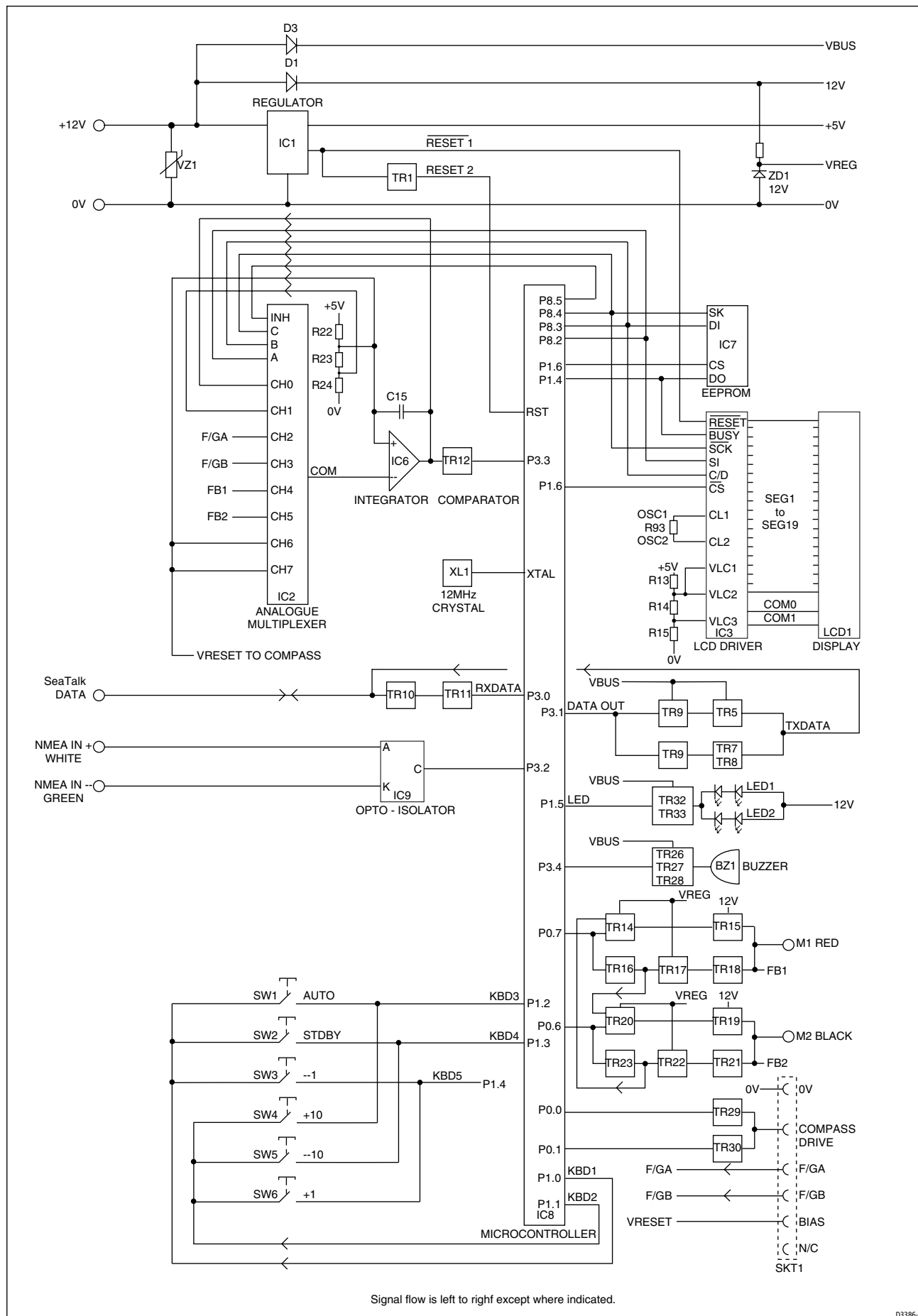

D3386-1

Figure 8. Block Diagram

7. Software History

Version	Change	Serial Number
P10	Introduction	12600001

83130t2a

8. Spares numbers

Item	Cat. No.	Comments
6-Pin Plug	D337	
6-Pin Socket	D338	
Plug and Socket Kit	D339	
Fluxgate Assembly	M022	
Drive Module	Q041	ST1000+
Drive Module	Q043	ST2000+
Lower Case	Q052	
Display Assembly	Q053	
Gearbox Kit	Q054	
PCB	Q218	LCD not included
Upper Case	W113	ST1000+
Upper Case	W114	ST2000+

8306113

9. Circuit Diagram and PCB Layout

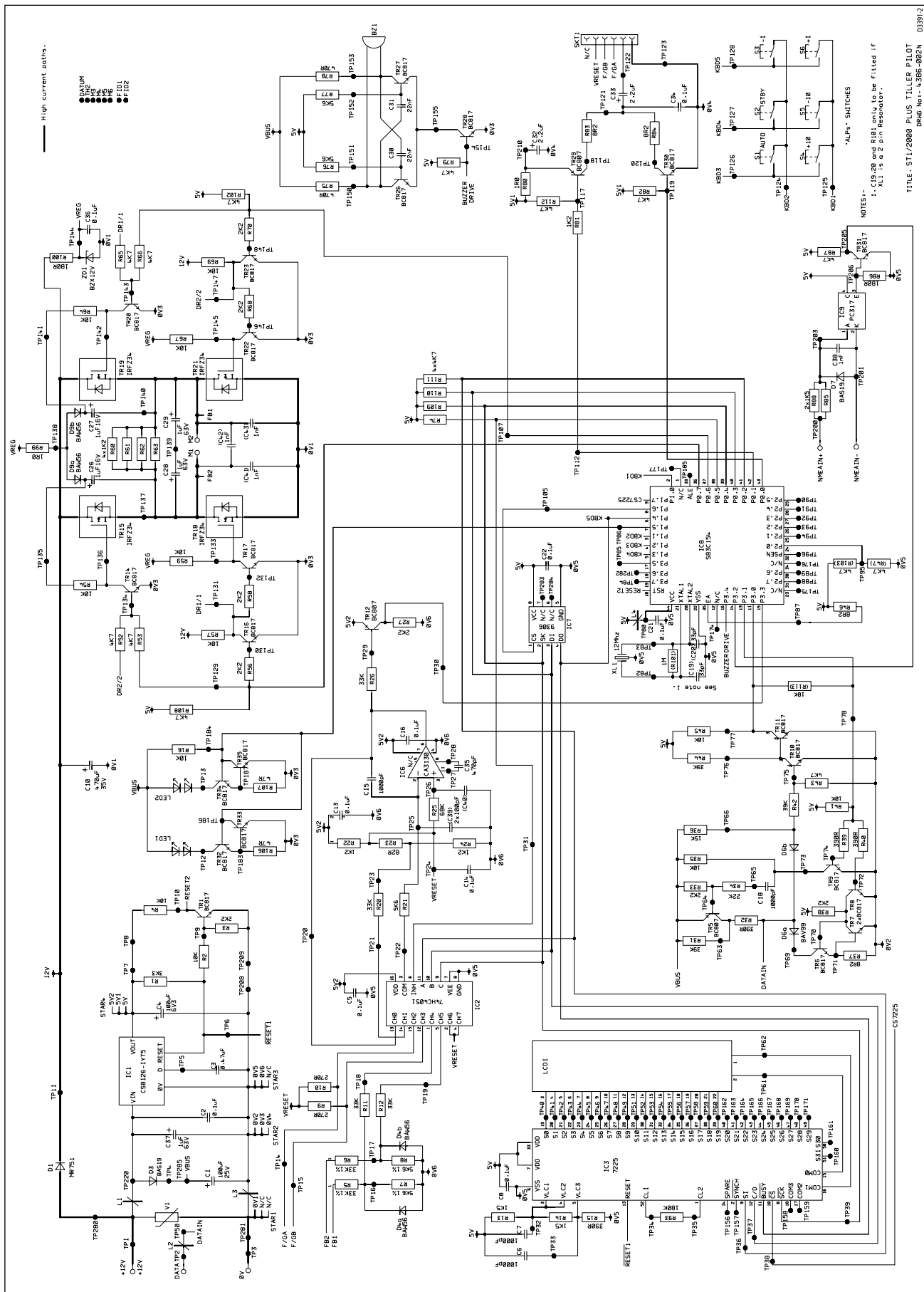
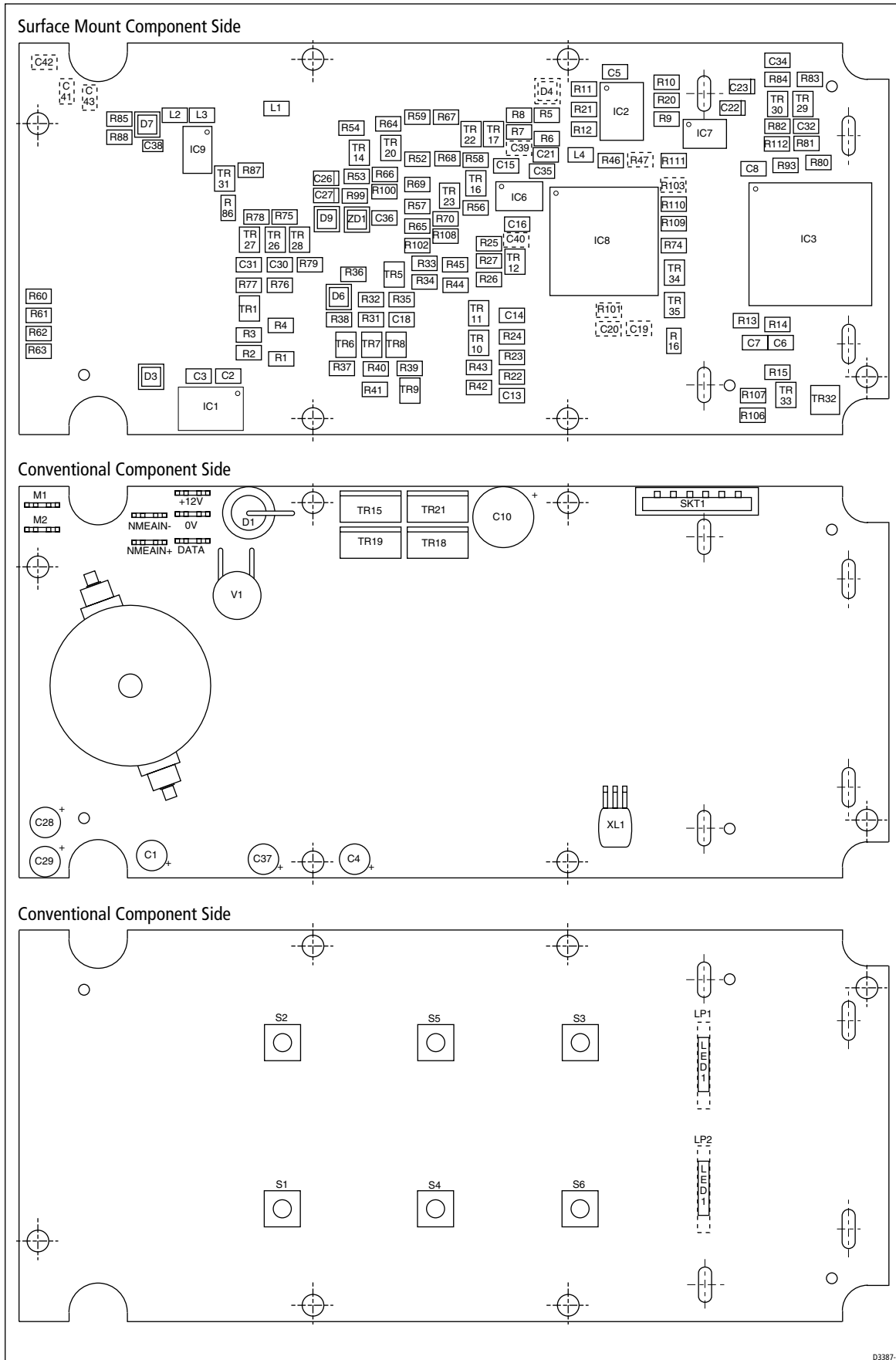

Figure 9. PCB Layout



D3387-1

Figure 10. PCB Layout

10. PCB Components List

Surface Mount Component Side

RESISTOR 1R0 5% 125mW	R80, 99
RESISTOR 8R2 5% 125mW	R37, 46, 83, 84
RESISTOR 47R 5% 125mW	R106, 107
RESISTOR 82R 1% 125mW	R23
RESISTOR 180R 5% 125mW	R86, 100
RESISTOR 270R 1% 125mW	R9, 10
RESISTOR 390R 5% 125mW	R15, 32, 39, 40
RESISTOR 470R 5% 125mW	R75, 78
RESISTOR 1K2 1% 125mW	R22, 24, 60, 61, 62, 63, 81
RESISTOR 1K5 5% 125mW	R13, 14, 85, 88
RESISTOR 2K2 5% 125mW	3, 27, 33, 38, 56, 58, 68, 70
RESISTOR 3K3 5% 125mW	R1
RESISTOR 4K7 5% 125mW	R43, (47), 52, 53, 65, 66, 74, 79, 82, 87, 102, (103), 108 - 112
RESISTOR 5K6 1% 125mW	R7, 8, 21, 76, 77
RESISTOR 10K 5% 125mW	R2, 4, 16, 35, 41, 45, 54, 57, 59, 64, 67, 69
RESISTOR 15K 5% 125mW	R36
RESISTOR 22K 5% 125mW	R34
RESISTOR 33K 1% 125mW	R5, 6, 11, 12, 20, 26
RESISTOR 39K 5% 125mW	R31, 42, 44
RESISTOR 68K 1% 125mW	R25
RESISTOR 180K 1% 125mW	R93
RESISTOR 1M0 1% 125mW	(R101)
CAPACITOR 33pF 5% COG 50V	(C19, 20)
CAPACITOR 100pF 10% CER 50V	(C39, 40)
CAPACITOR 470pF 10% COG 50V	C35
CAPACITOR 1000pF 2% COG 50V	C6, 7, 15, 18, 38, (41, 42, 43)
CAPACITOR 22nF 5% COG 50V	C3, 30, 31

8300116

Surface Mount Component Side (continued)

CAPACITOR 0.1uF 20% 50V AVX	C2, 5, 8, 13, 14, 16, 21, 22, 34, 36
CAPACITOR TANT 1uF 10% 16V	C26, 27
CAPACITOR 2.2uF 20% 6V3 SIZE A	C32, 33
DIODE SOT23 BAS 19	D3, 7
DIODE SOT23 BAV 99	D6
DIODE BAW 56	(D4), 9
DIODE ZENER BZX12V	ZD1
TRANSISTOR BC807 SOT23	TR5, 12, 29
TRANSISTOR BC817 SOT23	TR1, 6 - 11, 14, 16, 17, 20, 22, 23, 26, 27, 28, 30, 31, 33
TRANSISTOR BC868	TR32
ANALOGUE SWITCH 74HC401	IC2
LCD DISPLAY DRIVER 7225G-00 (NEC)	IC3
CA3130 OP AMP	IC6
EEPROM 16x16 M9306 1M1 SGS	IC7
MICROCONTROLLER S83C154 PLCC	IC8
OPTO ISOLATOR PC357	IC9
SOLID CHIP INDUCTOR	L1 - 4
PCB	3015 - 166

83130117

Resistor R101 (1M0) and capacitors (C19, C20) are fitted only if resonator XL1 (three legged version) is replaced by the two legged version.

Conventional component tables follow overleaf.

Conventional Component Side

CAPACITOR ELECTROLYTIC 1uF 20% 63V 2mm PITCH	C28, 29, 37
CAPACITOR 100uF TANT 20% 6V3 2.5mm PITCH	C4
CAPACITOR ELECTROLYTIC 100uF 20% 25V 7.5mm MAX DIAM	C1
CAPACITOR ELECTROLYTIC 470uF 20% 35V	C10
DIODE MR751	D1
TRANSISTOR FET LRFZ34 60V 30A	TR15, 18, 19, 21
REGULATOR +5V WITH RESET LM2925	IC1
VARISTOR ERZCO7DK270 ZNR TYPE 0	V1
BUZZER	BZ1
FLEXI CONNECTOR	SKT1
SPADE TERMINAL	7 off

And either

CERAMIC RESONATOR CERALOCK (3 PINS)	XL1
--	-----

or

CERAMIC RESONATOR CERALOCK (2 PINS)	XL2
--	-----

831308

See note on use of R101, C19, C20 with XL2.

Conventional Non - Component Side

LED DUAL SIDE FIRING GREEN	LED1, 2
MINIATURE AXIAL LAMP	(LP1, 2)
ALP SWITCH MINI	S1 - 6

831309

Raymarine Limited
Robinson Way, Anchorage Park, Portsmouth,
Hampshire, England PO3 5TD.

Tel: +44 (0) 23 9269 3611
Fax: +44 (0) 23 9269 4642
www.raymarine.com

Raymarine Incorporated
22 Cotton Road, Unit H, Nashua,
New Hampshire 03063-4219, USA

Tel: +1 603 881 5200
Fax: +1 603 864 4756
www.raymarine.com

