

H2183

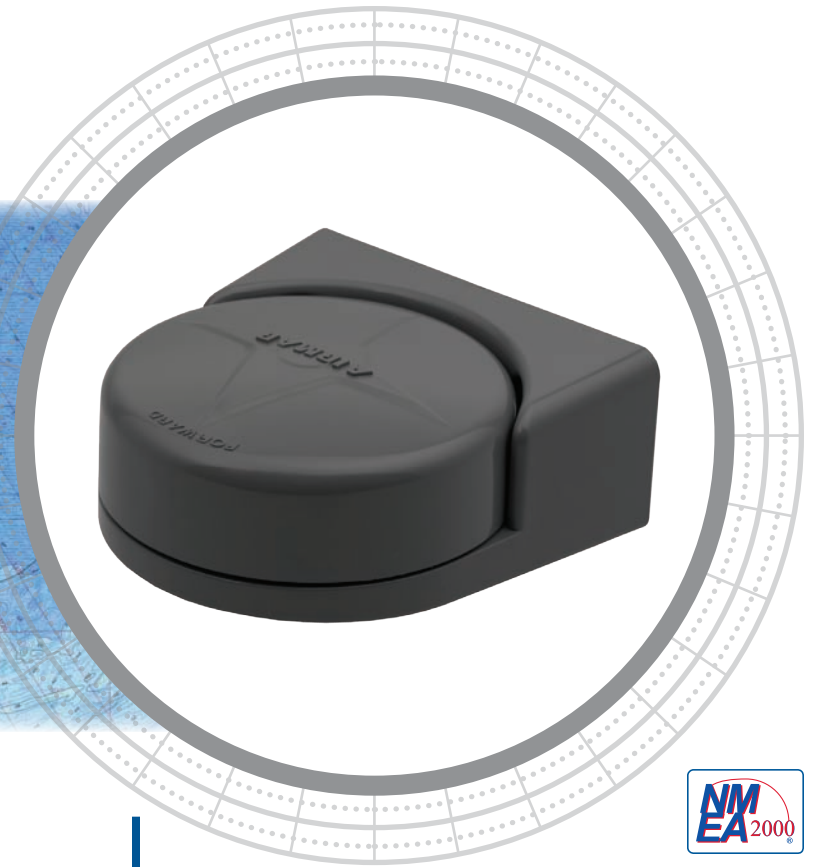

The Advantage is the Accuracy

Whether you are offshore fishing or just enjoying family time on the water, feel confident and comfortable that the H2183 is your reliable source for heading information. The solid-state three-axis compass, combined with Airmar's additional advanced sensors and software provide unparalleled performance. What sets the H2183 apart from the competition is its ability to maintain 2° of heading accuracy under dynamic motion conditions, such as steep heeling, hard turns, and rough seas. Heading integrated with the three-axis rate gyro and three-axis accelerometer data allows the H2183 to maintain 2° of accuracy even if the vessel is pitching and rolling up to 30°. This level of accuracy is perfect for interfacing with autopilots, chart plotters, and radar systems.

The H2183's innovative circular design easily mounts and aligns on ANY angled bulkhead. Designed for simultaneous use with NMEA 0183 and NMEA 2000® devices, the waterproof, easy-to-install sensor comes with a single cable which can be wired into both NMEA 0183 and NMEA 2000 networks on the vessel.

Customer Testimonials

"Our aluminum mussel dredge vessel has the new Airmar H2183 connected to a Simrad AP35 autopilot. It is installed below deck. The dredge runs off of the port side of the vessel which causes it to pull to port, thus counter-steering and autopilot precision are a must, especially since we dredge at 1 to 2 knots in 8 to 10 foot seas. The H2183 delivered stable and accurate heading to the Simrad AP35 autopilot over the manufacturer's compass. We are very impressed by the steering improvement of our autopilot at slow speeds when dredging over mussel beds. We couldn't get the same constant and stable heading using the existing autopilot's gyrocompass at slow speeds."
ASES Commercial Fisheries, France

Heading Sensor

Features

- Better than 1° heading accuracy in static conditions
- Best-in-class 2° heading accuracy in dynamic conditions
- Three-axis solid-state compass provides heading data
- Three-axis accelerometer provides pitch and roll data
- Three-axis rate gyro provides rate-of-turn data
- Only recreational heading sensor that uses a three-axis rate gyro
- Compass calibration can be easily done on any display or PC
- Easily mounts on any angled bulkhead
- IPX6 waterproof enclosure
- Default 10 Hz update rate for heading (HDG)
- Outputs NMEA 0183 and NMEA 2000 data simultaneously
- C2183 low-cost version available with 1° static and 5° dynamic heading accuracy

"As most of my days fishing for Cod and Tuna are 40 mile round-trip days off Gloucester, my autopilot is a necessity. The boat has a Simrad AP35 autopilot, a very popular commercial grade model. I replaced the manufacturer's heading sensor with the new Airmar H2183 and saw immediate steering improvement. The pilot steers straighter than ever, even when we are fishing in 6 to 8 foot seas. We especially use the pilot when we are trolling for tuna or cleaning cod and haddock while steaming home as we are not at the wheel 100% of the time."

Capt. Kevin Twombly, Kayman Charters, Gloucester, MA



Sensing Technology

www.airmar.com

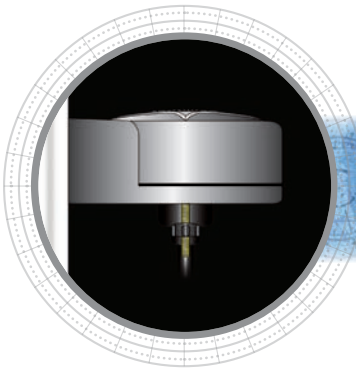

Technical Information

SPECIFICATIONS

- Static Compass Accuracy:** 1° RMS when level
- Dynamic Compass Accuracy:** 2° RMS (Best-in-Class)
- Heading Display Resolution:** 0.1°
- Settling Time:** 1 second (adjustable)
- Heading Data Output Update Rate:**
—10 Hz—NMEA 0183
—Adjustable up to 20 Hz—NMEA 2000®
- Rate-of-Turn Range:** 0° to 70° per second
- Rate-of-Turn Accuracy:** 1° per second
- Rate-of-Turn Data Output Update Rate:**
—2 Hz—NMEA 0183 (Adjustable up to 10 Hz)
—Adjustable up to 20 Hz—NMEA 2000®
- Pitch and Roll Range:** ±50°
- Static Pitch and Roll Accuracy:** <1°
- Dynamic Pitch and Roll Accuracy:** <3°
- Pitch and Roll Display Resolution:** 0.1°
- Pitch and Roll Boat Alignment:** Yes with software
- Pitch and Roll Data Output Update Rate:**
—2 Hz—NMEA 0183 (Adjustable up to 10 Hz)
—Adjustable up to 20 Hz—NMEA 2000®
- Supply Voltage:** 9 VDC to 16 VDC
- Supply Current:** <140 mA
- NMEA 2000® Load Equivalency Number (LEN):** 3
- Certifications and Standards:** CE, IPX6, RoHS, IEC60945

DATA OUTPUT PROTOCOL

- NMEA 0183 Sentence Structure**
- \$HCHDG..... Heading, Deviation, and Variation
 - \$HCHDT..... Heading Relative to True North
 - \$TIROT..... Rate of Turn
 - \$YXXDR..... Transducer Measurements: Vessel Attitude

NMEA 2000® Supported PGNs

- 127250..... Vessel Heading
- 127251..... Rate of Turn
- 127257..... Attitude

DIMENSIONS

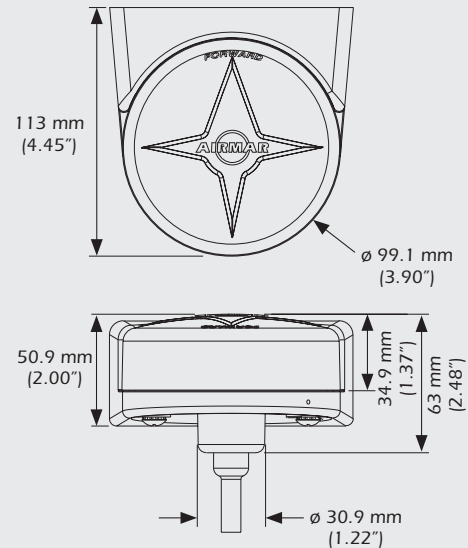

Adjustable bracket design allows for adjusting H2183 toward the Bow, in any mounting location.

