

SmartPilot X-5 Wheel Installation & Setup Guide

Document reference: 87074-4

Date: July 2012

Autohelm, HSB, RayTech Navigator, Sail Pilot, SeaTalk and Sportpilot are UK registered trademarks of Raymarine UK Limited.

Pathfinder and Raymarine are UK registered trademarks of Raymarine Holdings Limited.

45STV, 60STV, AST, Autoadapt, AutoGST, AutoSeastate, AutoTrim, Bidata, G Series, HDFI, LifeTag, Marine Intelligence, Maxiview, On Board, Raychart, Raynav, Raypilot, RayTalk, Raystar, ST40, ST60+, Seaclutter, Smart Route, Tridata and Waypoint Navigation are trademarks of Raymarine UK Limited.

All other product names are trademarks or registered trademarks of their respective owners.

Contents

Preface	v
Safety notices	v
EMC Conformance	v
Limitations on pressure washing	v
Product documents	vi
Warranty	vi
Product disposal	vi
Waste Electrical and Electronic (WEEE) Directive	vi
Chapter 1: Installation and system overviews	1
1.1 Installation overview	1
Planning	1
Installing	1
1.2 Safe and successful installation	1
Certified installation	1
Getting assistance	1
1.3 System overviews	2
Marine electronics systems	2
Example SeaTalk system	3
1.4 Equipment & tools	4
Parts supplied	4
Tools and equipment NOT supplied	5
Tools:	5
Cables / equipment	5
Optional equipment	5
1.5 Create a schematic diagram	5
Chapter 2: Installing the system	7
2.1 Installation precautions	7
EMC installation guidelines	7
Remember	7
Suppression ferrites	8
Connections to other equipment	8
Compass	8
2.2 General cabling guidelines	8
Power cable requirement	8
2.3 SPX-5 Wheel system Course Computer	9
Mounting	9
Connection overview	11
2.4 Mounting the Wheel Drive	11
Introduction	11
Step 1 – Drill the spoke clamp holes	12
Step 2 – Secure the wheel drive to the wheel	14
Step 3 – Attach the pedestal bracket	15
Motor tube location	15
Pedestal bracket – length and position	16
Wheel Drive electrical connection	19
Wheel Drive cable routing	20
2.5 Connecting power & drive cables to the Course Computer	21
Power	21
Circuit breaker/fuse	21

	Cable	21
	Connection procedure	21
2.6	Fluxgate Compass	22
	Compass mounting	22
	Location	22
	Mounting procedure	23
	Compass connection	23
2.7	Pilot Controller	24
	Fitting	24
	Connecting to SeaTalk	24
	SeaTalk power connections	24
2.8	Connect to ground	26
2.9	Optional connections	27
	Rudder reference	27
	SeaTalkng Connections	28
	SeaTalkng power	28
	See also	28
	NMEA 0183 equipment	29
	Data bridging	29
	NMEA 0183 / Connecting other manufacturers' equipment	29
2.10	Final checks	30
	Secure all cables	30
2.11	Commission the system before use	30
Chapter 3: Commissioning & setup		31
	Requirement	31
3.1	Commissioning	31
	Dockside checks & setup	31
	Switching on	31
	Checking SeaTalk and NMEA 0183 connections	32
	SeaTalk instruments	32
	SeaTalk and NMEA GPS or Chartplotter	32
	Other NMEA 0183 connections	32
	Checking autopilot operating sense	32
	Setting the vessel and drive type	33
	Set the vessel type	34
	Set the drive type	34
	Align the rudder indicator	34
	Set the rudder limits	34
	Save the new settings	35
	Seatrial calibration	35
	Important	35
	Seatrial conditions	35
	Compass calibration	35
	Swinging the compass	35
	Aligning the compass heading	37
	AutoLearn	38
	Commissioning complete	40
3.2	Manual setup	41
	Checking SPX-5 Wheel system operation	41
	Response level	41
	Rudder gain	42
	Checking	42
	Adjusting	42
	Counter rudder	43

Checking.....	43
Adjusting.....	43
AutoTrim	43
Adjusting.....	43
Chapter 4:SPX-5 Wheel system settings	45
4.1 Introduction	45
Calibration modes	45
Display calibration	45
User calibration.....	45
Seatrial calibration.....	45
Dealer calibration.....	45
Accessing the Calibration modes	46
Adjusting calibration values	46
4.2 Display calibration	47
RUDD BAR screen	47
HDG screen	47
Data pages	47
Setting up data pages.....	48
4.3 User calibration	49
AutoTack	50
Gybe inhibit	50
Wind selection.....	50
WindTrim.....	50
Response level.....	50
4.4 Dealer calibration	51
Seatrial calibration lock	52
Vessel type	52
Drive type	53
Align rudder.....	53
Rudder limit	53
Rudder gain	53
Counter rudder	53
Rudder damping.....	54
AutoTrim	54
Response level	54
Turn rate limit.....	55
Off course angle	55
AutoTack	55
Gybe inhibit	56
Wind selection.....	56
WindTrim.....	56
PowerSteer	56
Cruise speed.....	56
Latitude	56
System reset	57
4.5 System defaults	57

Appendix 1:NMEA 0183 sentences	59
NMEA0183 to Course Computer	59
NMEA0183 from Course Computer	59
Appendix 2:SPX-5 Wheel system specifications	61
Course Computer	61
Wheel Drive	62
Pilot Controller (ST6002)	63
Index.....	65

Preface

Safety notices



WARNING: Product installation & operation

This equipment must be installed, commissioned and operated in accordance with the Raymarine instructions provided.

Failure to do so could result in personal injury, damage to your boat and/or poor product performance.



WARNING: Switch off power supply

Make sure you have switched off the power supply before you start installing this product.



WARNING: Navigational safety

Although we have designed this product to be accurate and reliable, many factors can affect its performance. Therefore, it should serve only as an aid to navigation and should never replace commonsense and navigational judgement. Always maintain a permanent watch so you can respond to situations as they develop.

EMC Conformance

All Raymarine equipment and accessories are designed to the best industry standards for use in the recreational marine environment. Their design and manufacture conforms to the appropriate Electromagnetic Compatibility (EMC) standards, but correct installation is required to ensure that performance is not compromised.

Limitations on pressure washing

CAUTION: Do not pressure wash Raymarine products

Raymarine products must NOT be subjected to water pressures in excess of CFR46 / IPX6 standards (for example, as generated by commercial high pressure washing equipment). Products subjected to water at these high pressures may experience water intrusion and subsequent failure.

Raymarine products are waterproofed to CFR46 / IPX6 standards, which means that when installed and operated in accordance with the appropriate product documentation, they can be used in most weather and sea conditions. However, any exposure to high-pressure water that exceeds the CFR46 / IPX6 standards, on or around Raymarine products will invalidate the warranty for those products.

Product documents

This document is part of a series of books associated with the SmartPilot X-5 series. Documents can be downloaded from www.raymarine.com/handbooks.

Title	Part number
SmartPilot X-5 Wheel Operating Guide	81302
SmartPilot X-5 Wheel Installation and Setup Guide	87074
ST6002 Controller installation sheet	87058
ST6002 SmartPilot Controller - Wheel Quick Reference Guide	86130
Fluxgate compass installation sheet	87011
Warranty Booklet	80017

To the best of our knowledge, the information in the product documents was correct when they went to press. However, Raymarine cannot accept liability for any inaccuracies or omissions in product documents.

In addition, our policy of continuous product improvement may change specifications without notice. Therefore, Raymarine cannot accept liability for any differences between the product and the accompanying documents.

Warranty

To register your new Raymarine product, please take a few minutes to fill out the warranty card. It is important that you complete the owner information and return the card to us to receive full warranty benefits. You can also register online at www.raymarine.com by following the **Login or create an account** link.

Product disposal



Waste Electrical and Electronic (WEEE) Directive

The European WEEE Directive requires that waste electrical and electronic equipment is recycled.

Products carrying the crossed out wheeled bin symbol (illustrated above) must not be disposed of in general waste or landfill, but in accordance with local regulations for such products.

Although the WEEE Directive does not apply to all Raymarine products, we support its policy and ask you to be aware of the correct method for disposing of such products.

Please contact your local dealer, national distributor or Raymarine Technical Services for information on product disposal.

Chapter 1: Installation and system overviews

This chapter gives an overview of installation procedures and network configurations for an SPX -5 Wheel system.

1.1 Installation overview

There are two stages to installing an SPX -5 Wheel system, namely planning the installation, then installing and mounting the components.

It is important to carry out the planning stage, to ensure that all components used in the system, including cables and accessories, are correctly specified and located.

The following is a summary of the tasks in each stage.

Planning

1. Understand your system.
2. Check equipment supplied.
3. Establish suitable locations for the autopilot equipment.
4. Plan cabling and connections.
5. Produce a schematic diagram.

Installing

1. Mount SPX-5 Course Computer.
2. Install Wheel Drive unit.
3. Install the autopilot controller.
4. Install the compass.
5. Connect power cables and system ground.
6. Connect additional equipment / cables to the Course Computer.
7. Final fix: secure all equipment in place; secure all cables.

1.2 Safe and successful installation

To achieve a safe and reliable installation of your SPX-5 Wheel system, installation must be carried out by a competent professional who should adhere to the instructions in this guide.

Certified installation

Raymarine recommends certified installation by a Raymarine approved installer. A certified installation qualifies for enhanced warranty benefits. Contact your Raymarine dealer for further details and refer to the separate warranty document packed with your product.

Getting assistance

If you need further assistance with an installation, contact your dealer or visit the Raymarine web site www.raymarine.com.

1.3 System overviews

The SPX-5 Wheel system consists of a number of components connected together using a Raymarine SeaTalk bus.

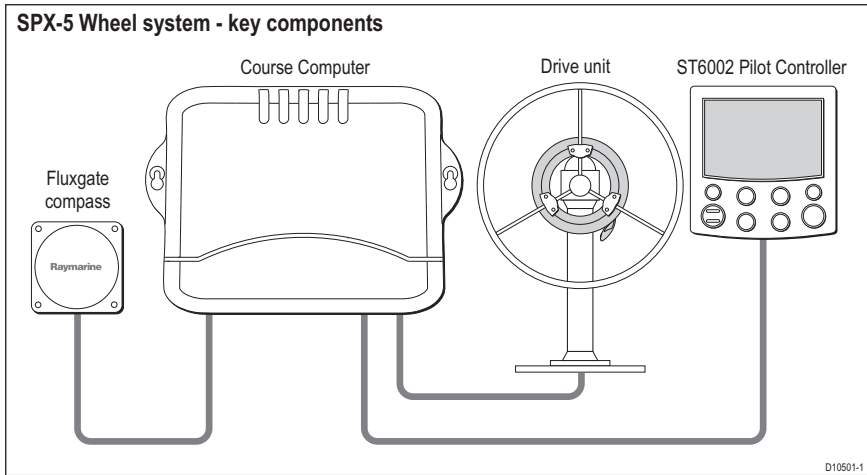

Marine electronics systems

The autopilot may form part of your wider ships electronics system. It may be connected to equipment using a number of marine industry standard protocols, including:

- SeaTalk.
- SeaTalk^{ng}
- NMEA 0183

Example SeaTalk system

SeaTalk allows connection of compatible instruments and equipment through a dedicated data bus. This allows information sharing around the ship's electronics system.

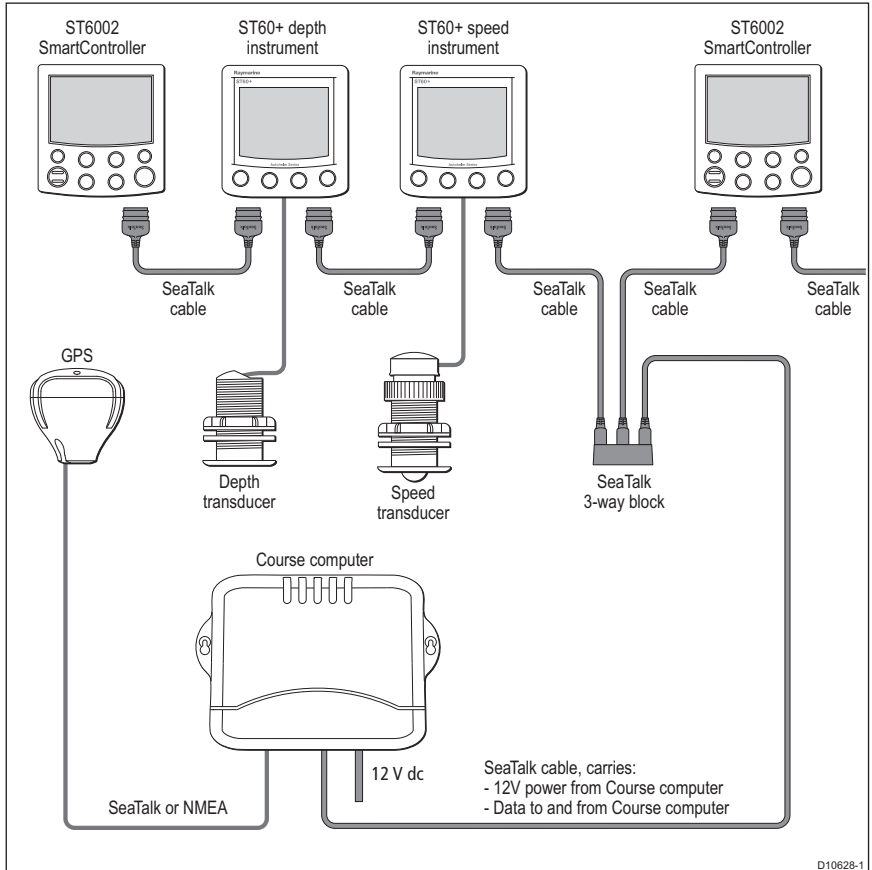

1.4 Equipment & tools

Before you begin ensure you have all the necessary components and tools to install your system.

Parts supplied

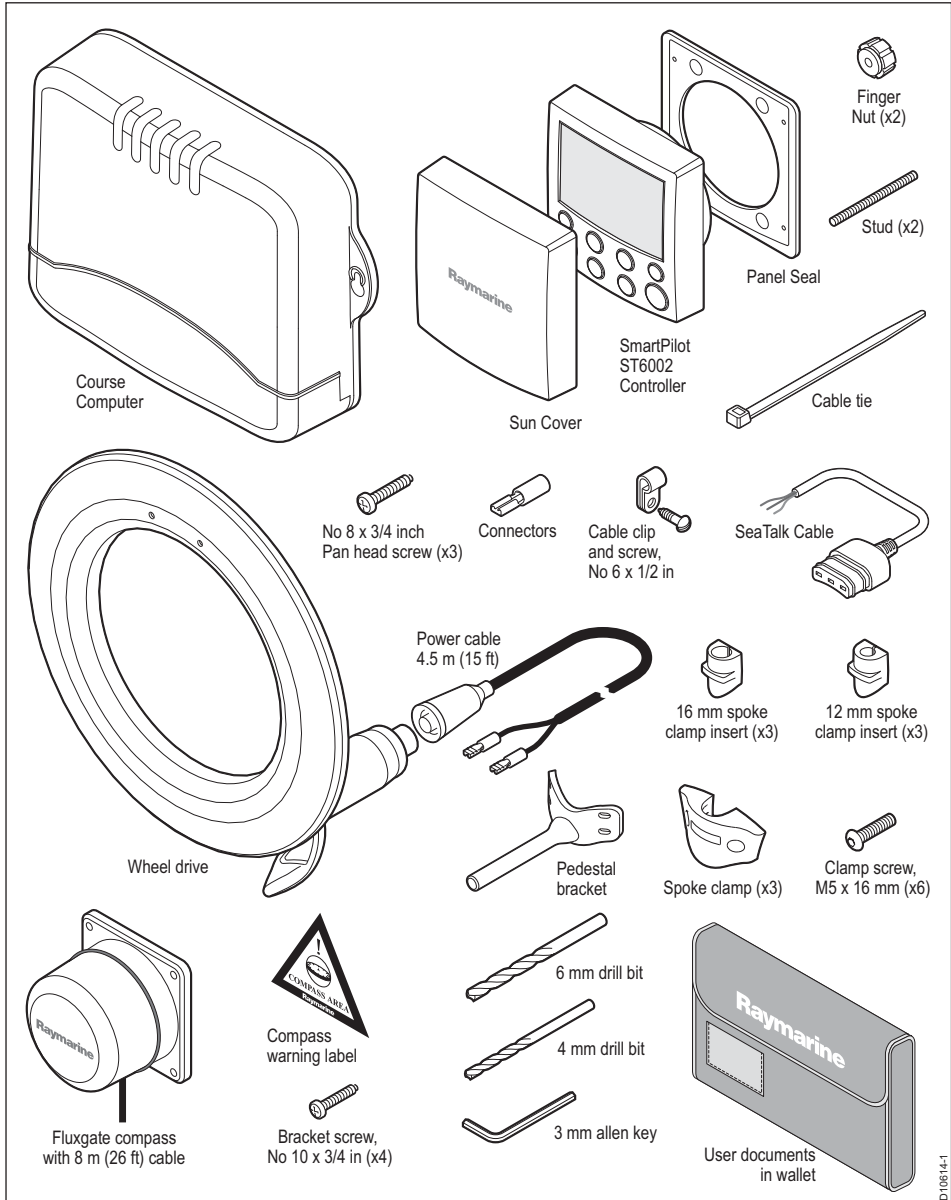

Tools and equipment NOT supplied

You will need to supply the following equipment and tools:

Tools:

- Cross-head/pozi-drive screwdriver.
- Pliers.
- Power drill (cordless recommended).
- Bearing puller to remove steering wheel.
- Tape measure (metric/imperial).
- Hammer and center punch.
- Pencil, masking tape.
- Spanner (Wrench) to fit wheel nut.
- Washing-up liquid (to lubricate the spokes).
- Hacksaw.
- Power/battery Drill.
- 4 mm + 6 mm drill bits (supplied).
- 3 mm allen key (Hex key, supplied).

Cables / equipment

- Power cable and fuse/breaker.
- Additional data cables (e.g. for connection of GPS or chartplotter).
- Grounding braid.

Optional equipment

- Bulkhead fitting kit, Raymarine part number E15017, if your wheel is bulkhead or box pedestal mounted.
- Additional spoke clamp, Raymarine part number A18089. Enables you to fit an extra clamp to a 4-spoke wheel, for esthetic reasons.

1.5 Create a schematic diagram

As part of the preparation for installing your SPX-5 Wheel system, we recommend that you create a schematic diagram representing the system you want to install. This will help ensure that you install a safe optimum system, and so is particularly important if you intend connecting your autopilot to other electronic equipment.

The schematic diagram should include:

- Location of all components. See *page v* and *page 7* for EMC guidelines that may affect the location of specific components.
- Connectors, cable types, routes and lengths.

When you have completed the schematic diagram, you are ready to begin installing the SPX-5 Wheel system.

Chapter 2: Installing the system

Before proceeding with the installation you should have the following to hand:

- All necessary equipment and tools to install your SPX-5 Wheel system.
- The correct type and length of power cable.
- Schematic diagram detailing autopilot system location and connections.

You should also check that existing marine electronics, such as the GPS are installed and working.

2.1 Installation precautions



WARNING: Install at dockside

For safety reasons your boat must be at dockside before commencing installation.

CAUTION: Switch off power supply

Switch off the power supply before you start installing this product.

EMC installation guidelines

Raymarine equipment and accessories conform to the appropriate Electromagnetic Compatibility (EMC) regulations. This minimizes electromagnetic interference between equipment, which could otherwise affect the performance of your system.

Correct installation is required to ensure that EMC performance is not compromised.

For optimum EMC performance, we recommend that:

- Raymarine equipment and the cables connected to it are:
 - i. At least 3 ft (1 m) from any equipment transmitting or cables carrying radio signals e.g. VHF radios, cables and antennas. In the case of SSB radios, the distance should be increased to 7 ft (2 m).
 - ii. More than 7 ft (2 m) from the path of a radar beam. A radar beam can normally be assumed to spread 20 degrees above and below the radiating element.
- The product is supplied from a separate battery from that used for engine start. This is important to prevent erratic behavior and data loss which can occur if the engine start does not have a separate battery.
- Raymarine specified cables are used.
- Cables are not cut or extended unless doing so is detailed in the installation manual.

Remember

Where constraints on the installation prevent any of the above recommendations:

- Always allow the maximum separation possible between different items of electrical equipment. This will provide the best conditions for EMC performance for the installation.

Suppression ferrites

Raymarine cables may be fitted with suppression ferrites. These are important for correct EMC performance. Any ferrite removed to facilitate installation must be replaced in the original position immediately after the installation is complete.

- Use only ferrites of the correct type, supplied by Raymarine authorized dealers.

Connections to other equipment

If Raymarine equipment is to be connected to other equipment using a cable not supplied by Raymarine, a Raymarine suppression ferrite **MUST** always be attached to the cable near the Raymarine unit.

Compass

The compass is sensitive to magnetic influences and other potential sources of interference including engines and VHF radio waves. To ensure optimum operation it is essential to locate the compass correctly.

2.2 General cabling guidelines

- Do not mix ac and dc cables.
- Adhere to EMC guidelines (see *page 7*).
- Use Copex conduit where appropriate to protect cables.
- Label all cables for easy identification.
- Keep the Fluxgate compass cable separate from other cables.

Power cable requirement

An overview of the power cables is given in the following illustration.

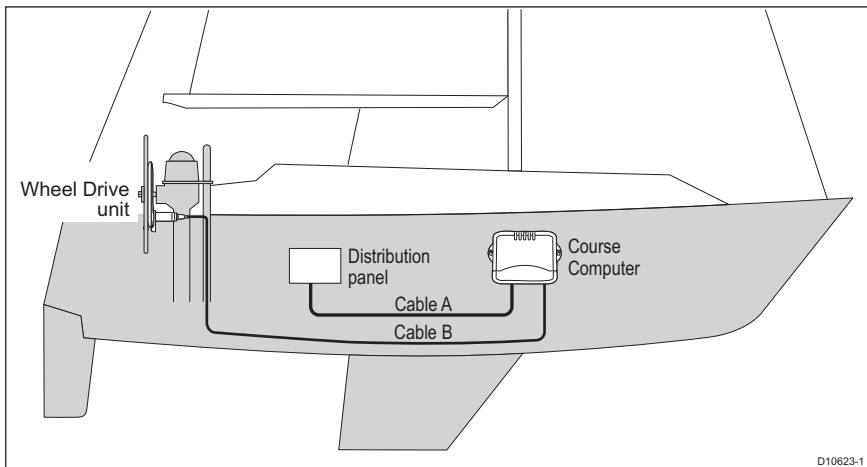

CAUTION: Power cable

Using an incorrect size of power cable could reduce the power supplied to the drive unit and therefore cause your SPX-5 Wheel system to malfunction. Ensure the correct cable size is used. If in doubt, use a heavier gauge cable.

The requirement for power cables depends on the total length of the power circuit. In the above illustration, that is the total length of Cable A + Cable B.

The correct cable dimensions for various cable lengths are given in the following table.

Total cable length (A + B)	Copper area	AWG
Up to 2.5 m (8 ft)	1.0 mm ²	18
Up to 4.0 m (13 ft)	1.5 mm ²	16
Up to 6.0 m (22 ft)	2.5 mm ²	14

2.3 SPX-5 Wheel system Course Computer

Mounting

The Course Computer must be mounted on a secure vertical surface, free from vibration.

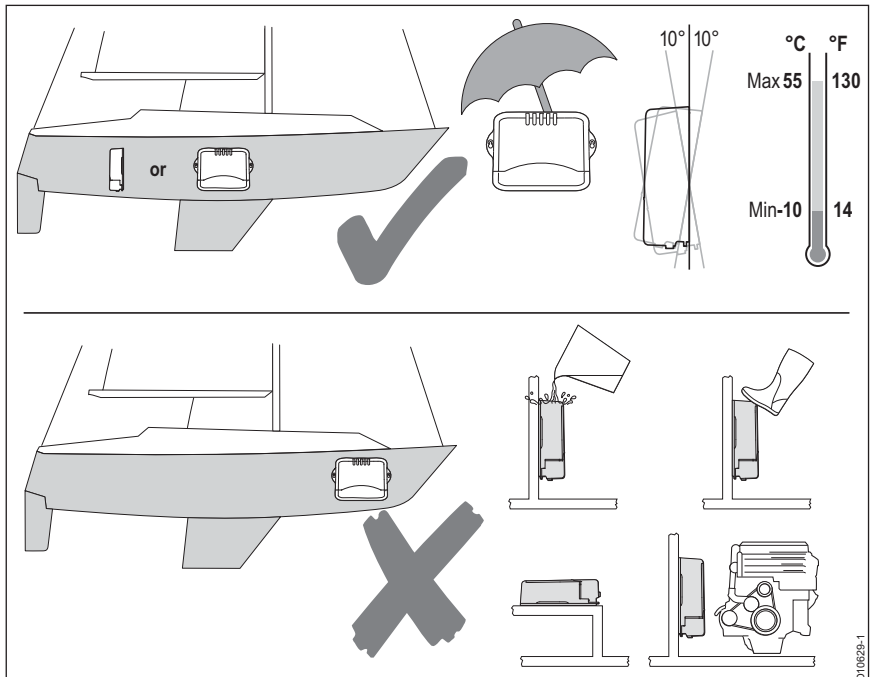

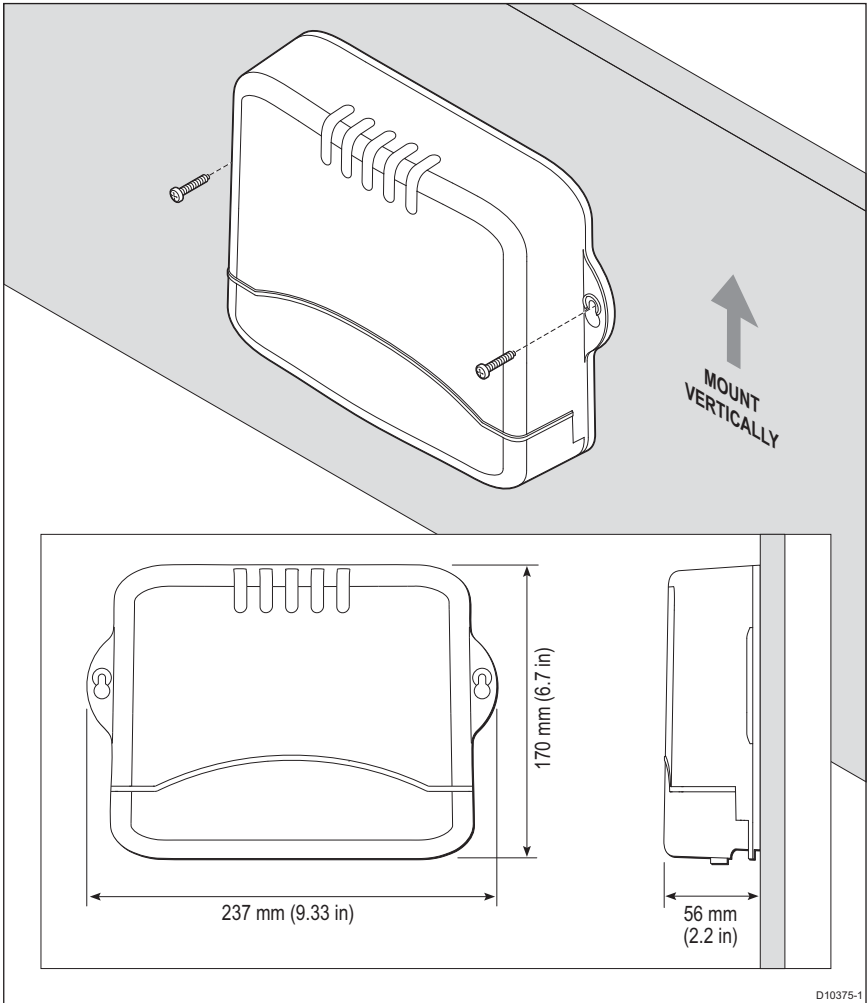

Connection overview

The Course Computer provides the following system connections:

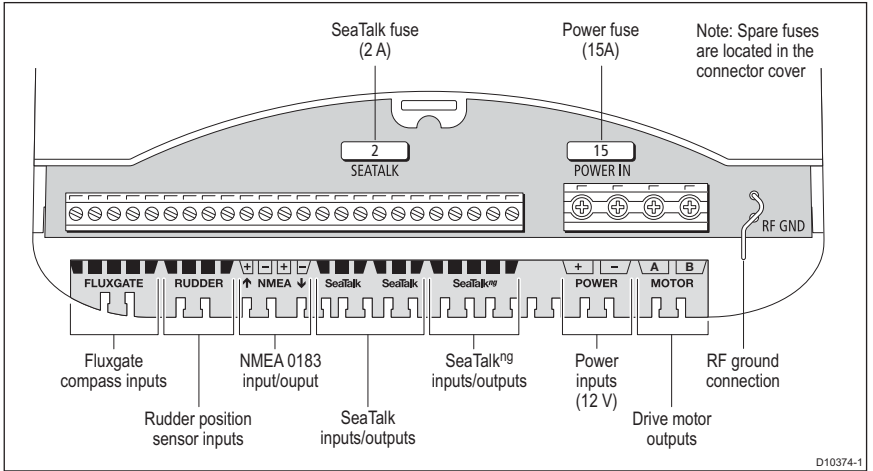

2.4 Mounting the Wheel Drive

Introduction

The Wheel Drive fits onto your boat's steering wheel. The Wheel Drive is compatible with 3, 4, 5, 6, 7 or 8 spoke wheels, and with steering systems having between 1 to 3.5 turns lock to lock.

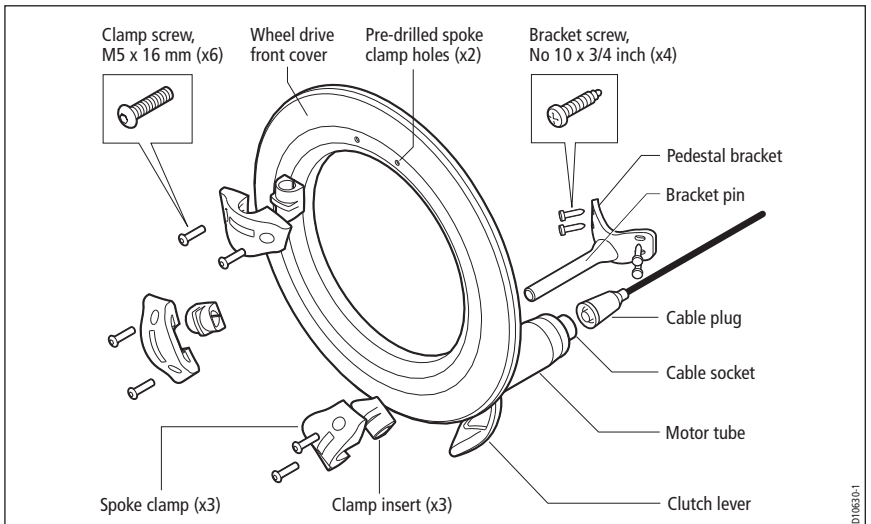

To install the wheel drive you need to:

1. Drill the spoke clamp holes in the front cover.
2. Securing the wheel drive to the wheel.
3. Attaching the pedestal bracket.

Step 1 –Drill the spoke clamp holes

1. Remove the wheel drive front cover:

- The front cover is held onto the wheel drive by three 'push-fit' posts which sit in three sockets on the drive ring.
- To remove the cover, hold the motor in one hand and use your other hand to pull the cover up and away from the drive unit (as shown below).

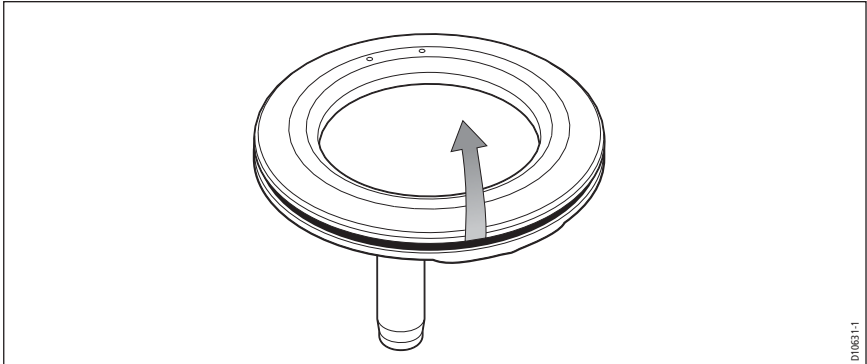

2. Identify the appropriate spoke clamp holes for your wheel. With the arrow at the top, refer to the following diagrams:

- The holes are numbered inside the cover (e.g. if you have a 5 spoke wheel, you need to drill the locations marked with '5').
- Mark the appropriate spoke clamp holes and check them by holding the cover against your wheel.

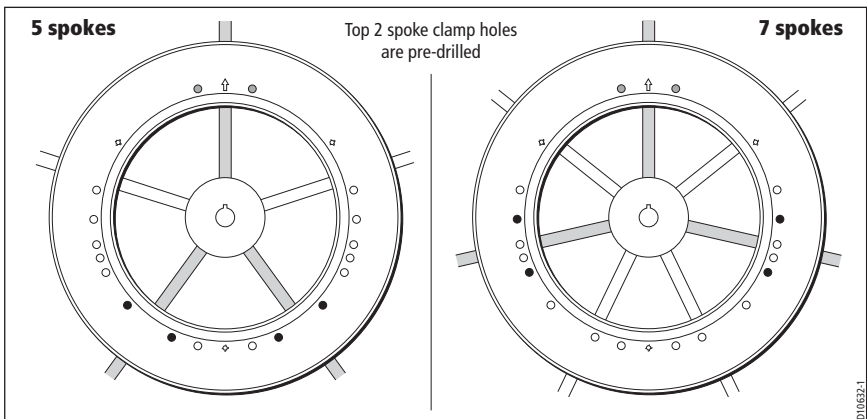

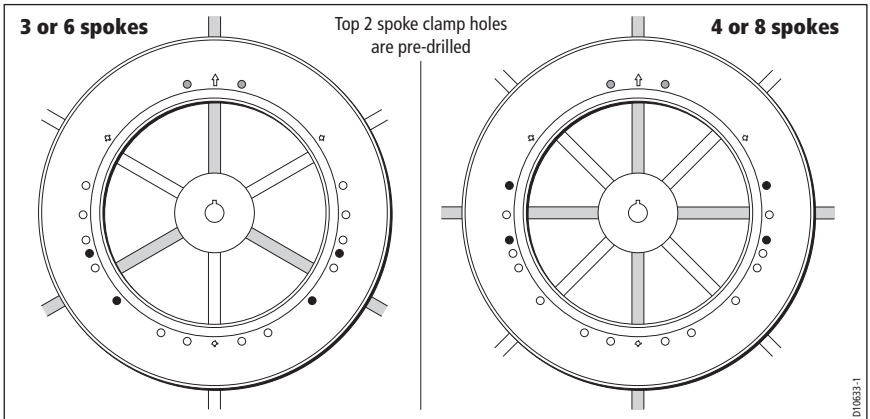

Note: *The wheel drive is designed to work with 3 spoke clamps on 4 and 8 spoke wheels. However, you may want to fit an extra spoke clamp to the fourth spoke, to give a symmetrical look to the installation. Raymarine dealers can supply an extra spoke clamp (part number A18089).*

3. Drill the appropriate spoke clamp holes using the larger of the supplied drill bits (6.0 mm or 1/4 in):
 - drill from the inside, placing a piece of scrap wood under the cover to produce a clean exit hole.
 - you will need to drill 4 new holes so the cover has 6 holes in total (2 for each spoke clamp).

Note: *The spoke clamps will cover these exit holes, so they will not be visible when the wheel drive is installed.*

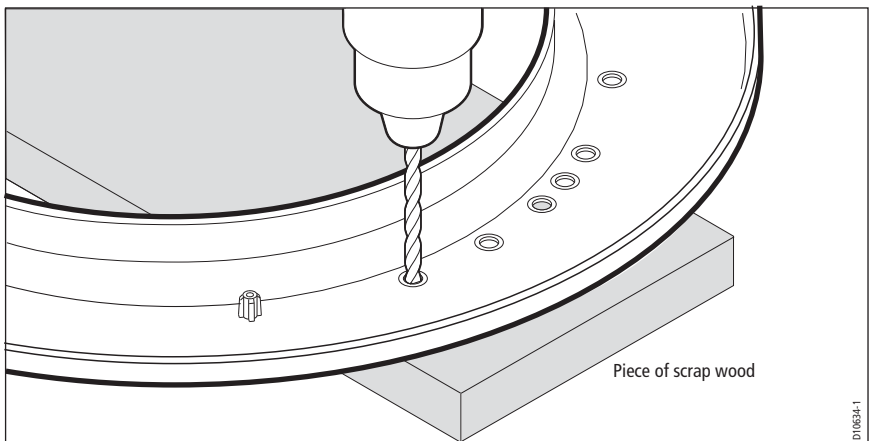

4. Align the cover with the wheel drive:
 - The two pre-drilled holes (marked with an arrow) must line up with their matching pair of threaded inserts on the drive ring (also marked with an arrow).
 - Make sure that the other spoke clamp holes align with their threaded inserts.

Note: *The cover will only fit back onto the wheel drive when the two parts are correctly aligned.*

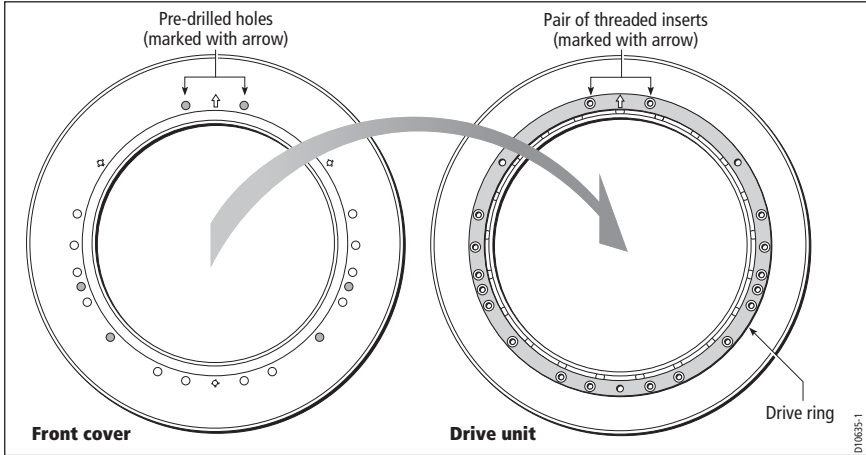

5. Fit the cover back onto the wheel drive, by pressing the cover in the three places shown in the diagram below, to push each post back into its locating socket.

Note: *This step is easier with the clutch engaged.*

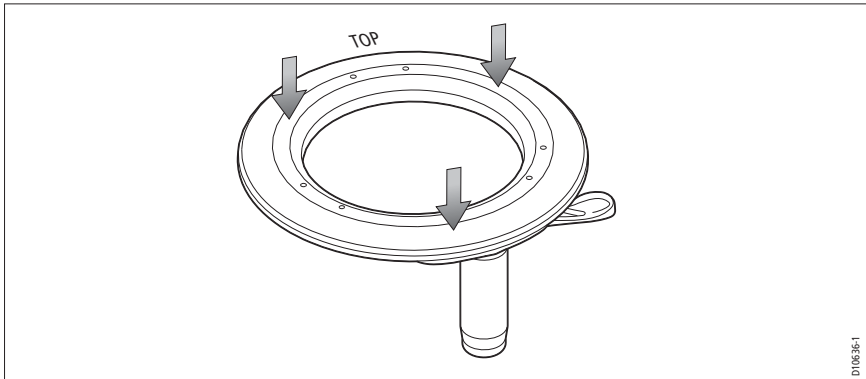

Step 2 – Secure the wheel drive to the wheel

1. Remove the wheel from the pedestal and place it on top of the drive unit, with the front of the wheel and drive both facing up.
2. Using the wheel drive template at the end of this book, select the correct set of spoke clamp inserts for your wheel:
 - Measure the spoke diameter at a distance of about 135 mm (5.3 in) from the center of the wheel.
 - Select the appropriate set of inserts: the wheel drive is supplied with 2 sets of 3 inserts suitable for 12 mm ($\frac{1}{2}$ in) and 16 mm ($\frac{5}{8}$ in) diameter spokes – each insert is marked with its size.

3. Fit the first spoke clamp as follows:
 - Lubricate the spoke with washing-up liquid – so you can slide the spoke clamp along the spoke to adjust its position.
 - Place the insert on the spoke about 135 mm (5.3 in) from the wheel center – this distance is not critical as the wheel drive will self-center as you fit all 3 spoke clamps.
 - Place the spoke clamp onto the insert, making sure that you have correctly located the clamp insert in the clamp.
 - Locate 2 of the clamp screws (M5 x 16 mm allen-head screws).
 - **Lightly** tighten the screws using the 3 mm allen key (Hex key, supplied).

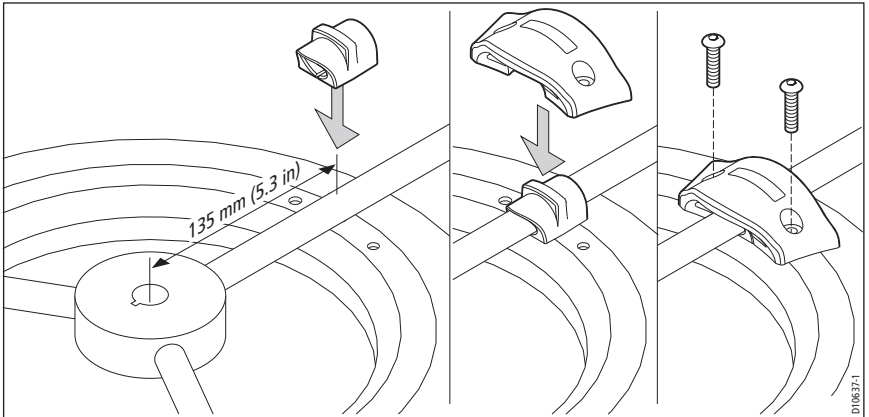

4. Repeat step 3 to fit the other 2 spoke clamps. As you fit each one, adjust the position of the wheel relative to the wheel drive so the holes in the clamp line up with the holes in the cover. **As you do this, the wheel drive will self-center on the wheel.**
5. After fitting all 3 spoke clamps, **fully tighten** the screws.

Step 3 – Attach the pedestal bracket

Note: *If your wheel is bulkhead or box pedestal mounted, you will need to obtain a bulkhead fitting kit (part number E15017) from your Raymarine dealer. Fitting instructions are supplied with the kit.*

Motor tube location

You can mount the wheel drive in either one of two ways, to give the most effective operation with your particular pedestal design and any adjacent obstructions:

- **Slot 1 installation:** the standard position uses slot 1 on the back of the wheel drive (the slot closest to the motor tube) so the motor tube is at the bottom to the right of the pedestal.
- **Slot 2 installation:** the alternative installation uses slot 2 to position the motor tube at the top to the left of the pedestal.

Select the appropriate slot so the motor tube is clear of obstructions.

CAUTION: Pedestal mounted compass

If you use slot 2 and you have a pedestal-mounted compass, the drive motor may affect compass readings.

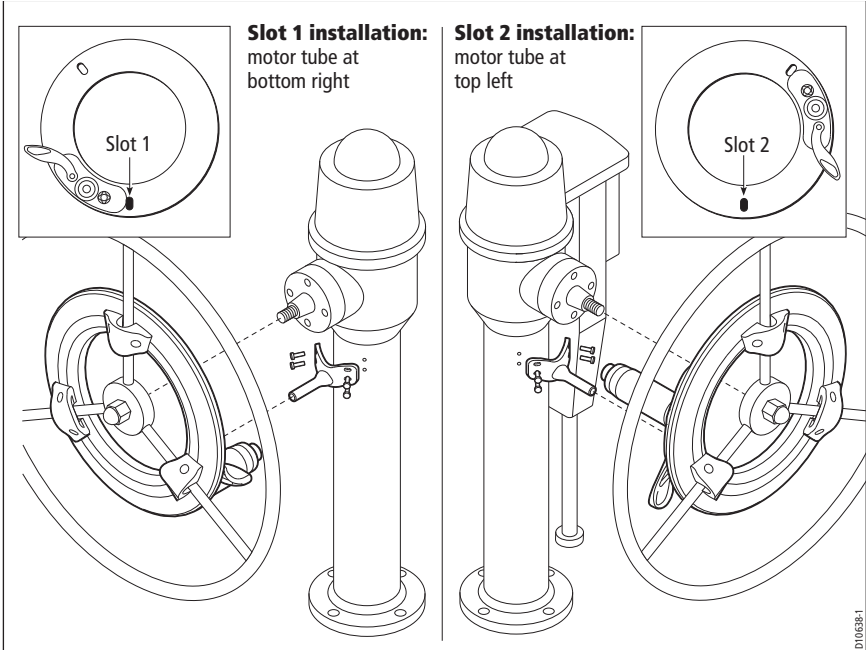
**Pedestal bracket – length and position**

Note: If you are replacing an existing 4000 wheel drive, you need to: remove the old pedestal bracket, cut the new bracket pin to the correct length (see steps 2 and 3 below), then secure it in the standard orientation using the existing pedestal holes.

1. Fit the wheel onto the pedestal, tighten the wheel nut to hold the wheel in place, and engage the wheel drive's clutch. Either:
 - lock the wheel in position with the appropriate slot centered at the bottom of the wheel
 - or
 - have an assistant hold the wheel in position so you can locate the bracket correctly.
2. Measure dimension A – the distance between the front of the pedestal and the rear edge of the drive's front cover (see diagram).

Note: You may find it easiest to hold the bracket below the wheel drive and mark dimension A directly on the pin.

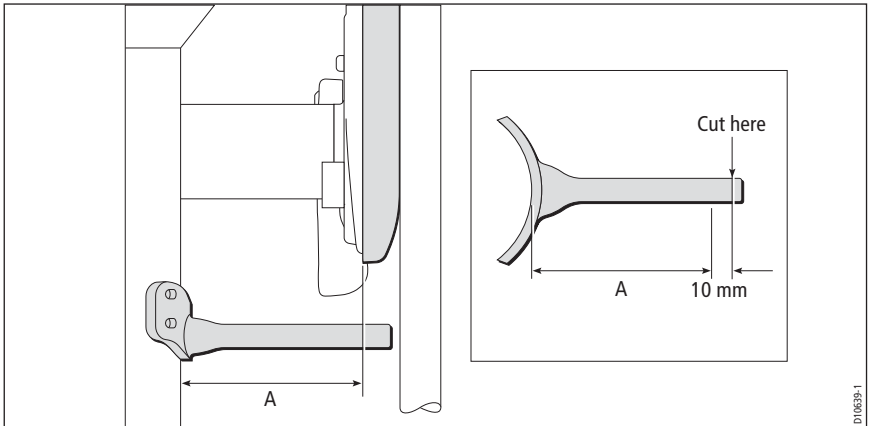

Note: If the wheel is bent or not running true, dimension A will change with the wheel position. Measure the smallest distance.

3. Use a hacksaw to cut the pin **10 mm (0.4 in) LONGER** than dimension A. Remove any sharp edges at the cut end with sandpaper or a file.
4. Place the pin end in slot 1 or 2 (as required).
 - To do this you may need to loosen the wheel nut so you can slide the wheel forward slightly, place the pin end in the slot, then return the wheel to its normal position and re-tighten the wheel nut

Note: You can install the pedestal bracket either way up. In the standard orientation the pin is at the bottom (below the mounting holes – see diagram). If obstructions on the pedestal prevent you from using the standard orientation, you can install the bracket so the pin is at the top (above the mounting holes).

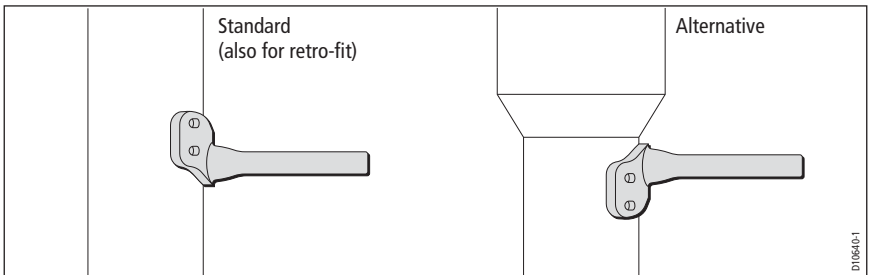

5. Making sure the slot is central at the bottom of the drive unit (6 o'clock position) and the pin is in the **middle** of the slot, carefully draw around the bracket.

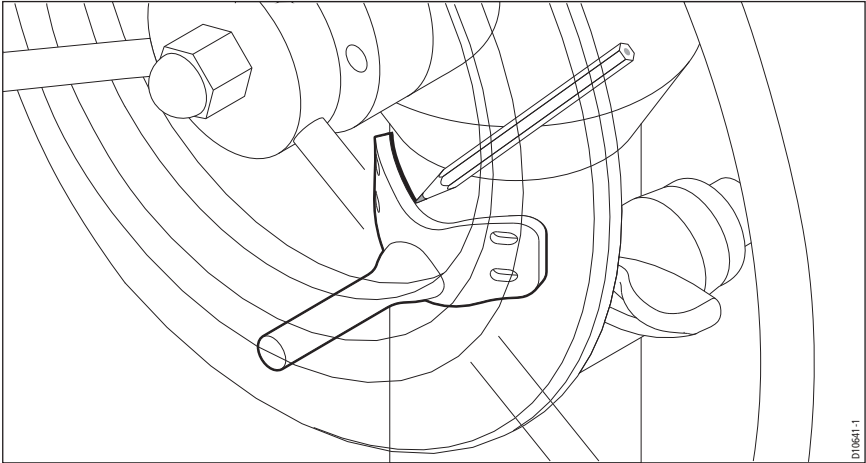

D10641-1

6. Remove the wheel, then hold the bracket on the pedestal in the location you have marked.
7. Check the position and alignment of the pedestal bracket:
 - the bracket pin should be aligned so it is directly below the pedestal spindle

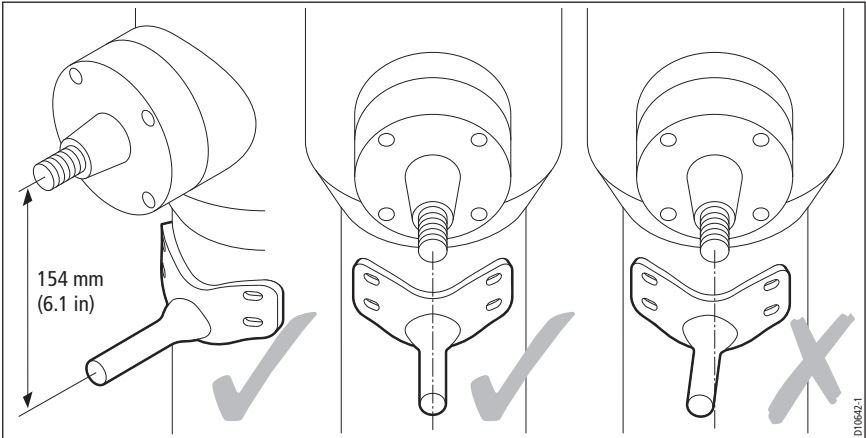

D10642-1

8. When the pedestal bracket is correctly positioned and aligned, mark around the inside of the slots, then remove the bracket.
9. Use a center-punch to mark the center of each slot, then use the smaller supplied drill bit to drill a 4.0 mm ($\frac{5}{32}$ in) diameter hole.

Note: *Drill at right angles to the pedestal surface.*

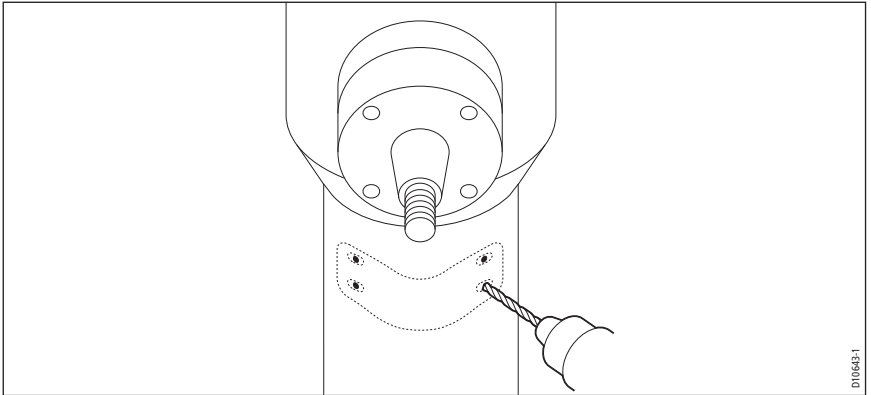

10. Hold the bracket in place then **lightly** tighten the four cross-head screws (No 10 x 3/4 in). As you do this, make sure the bracket is correctly aligned.
11. Replace the wheel, making sure that you locate the pin in the correct slot (slot 1 or slot 2).
12. Turn the wheel with the clutch off to check that the bracket is correctly positioned and aligned.

Note: If the wheel is bent or the wheel drive is off center, the pin will move up and down in the back plate slot. As long as the pin does not hit the top or bottom of the slot, this pin movement will not affect the drive unit's performance.

13. When you have checked alignment, **fully** tighten all four screws.

Wheel Drive electrical connection

The drive unit is supplied with 4.5 m (15 ft) of 2-core cable with a waterproof socket at one end. Connect the waterproof cable to the Wheel Drive socket as follows:

1. Ensuring correct alignment, push the plug firmly into the socket
2. Turn the locking ring 90° clockwise
3. Pull the plug cover across the plug and socket to make the connection waterproof.

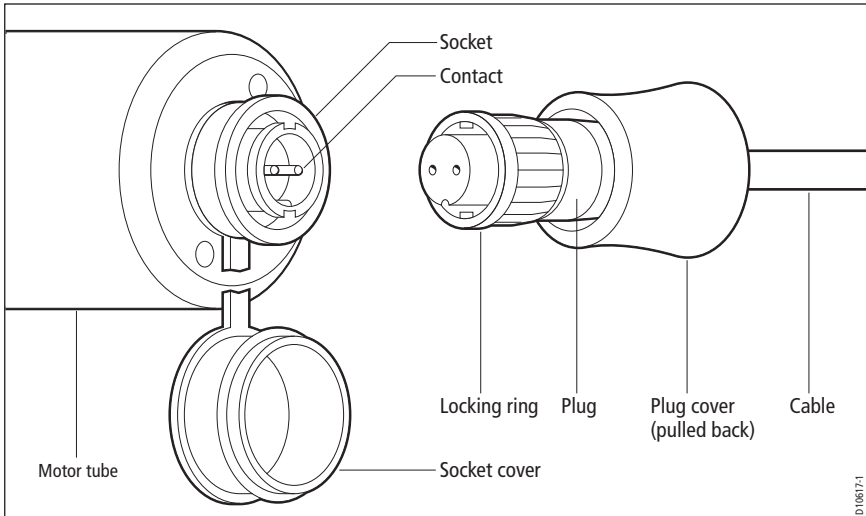

To disconnect the Wheel Drive cable connector, pull back the cover, turn the locking ring 90° anti-clockwise and pullout the connector. Place the attached cover on the Wheel Drive connector to protect it.

Wheel Drive cable routing

Route the free end of the Wheel Drive cable to the Course Computer, securing the cable as necessary at regular intervals along the route.

If the wheel pedestal has a cable duct, route the cable through this. In any case, ensure that you route the cable so it cannot foul the steering mechanism.

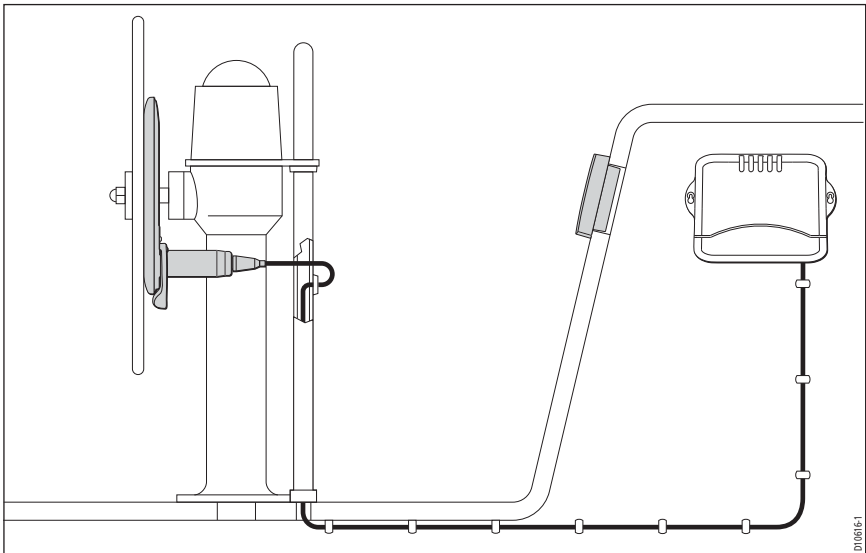

2.5 Connecting power & drive cables to the Course Computer

Power

The SPX-5 Wheel system needs a 12 V dc supply.

CAUTION: Ensure correct supply voltage

Do NOT connect 24 V to the Course Computer, or damage to the product could occur.

Circuit breaker/fuse

Protect the power supply for the SPX-5 Wheel system with a 10 A fuse or circuit breaker.

Cable

Using the information given at *Power cable requirement* on page 8, obtain the required length of the appropriate cable to connect power from the boat's distribution panel to the Course Computer.

Connection procedure

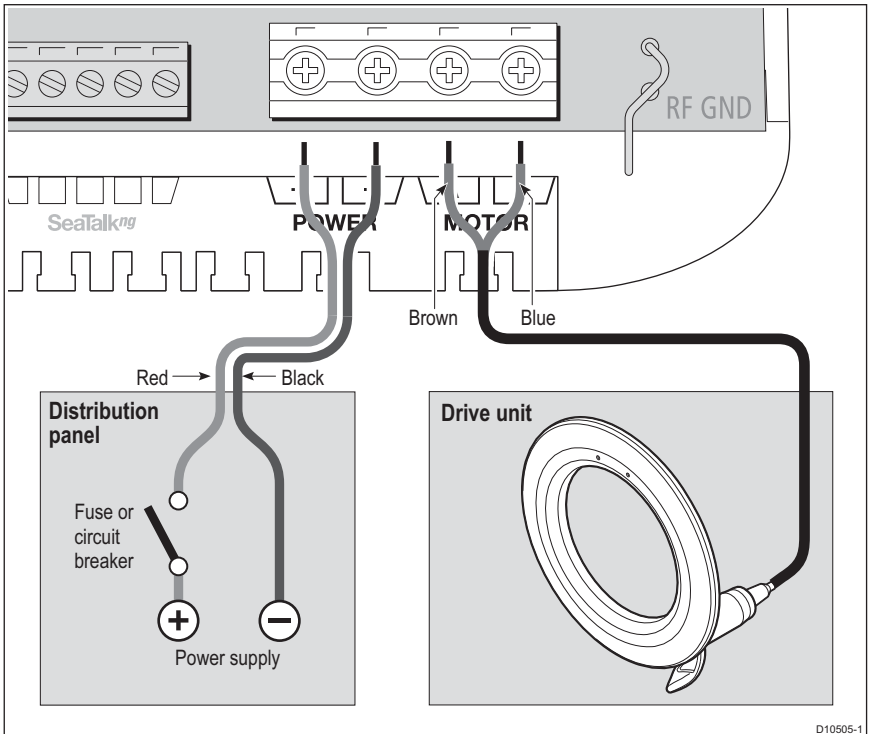

At the Course Computer, locate the free ends of the cables from the distribution panel and Wheel Drive. Ensuring all power is switched off, refer to the illustration above and connect each cable to the correct Course Computer terminals as follows:

1. Strip 8-10 mm (1/2 inch) of insulation from the end of each wire.
2. Use a small screwdriver to loosen the relevant screws on the terminal block.
3. Insert the stripped wires into the appropriate terminals then tighten the screws.

2.6 Fluxgate Compass

Use these instructions to install the Fluxgate Compass.

After fitting the Fluxgate Compass, ensure you affix the compass safe area label adjacent to the Fluxgate Compass.

The compass contains a self-levelling mechanism. This enables the compass to provide accurate readings with pitch and roll movements up to +/- 35°.

Note: When shaken, the Fluxgate Compass makes a rattling sound. This is entirely normal and is not a cause for concern.

Compass mounting

Location

To achieve the best performance, mount your compass:

- With the Raymarine logo facing the bow.
- As close as possible to the boat's pitch and roll center.
- At least 2ft 6 in (0.8 m) away from your boat's steering compass to avoid deviation of both compasses.
- As far away as possible from large iron masses, such as the engine or other magnetic devices.

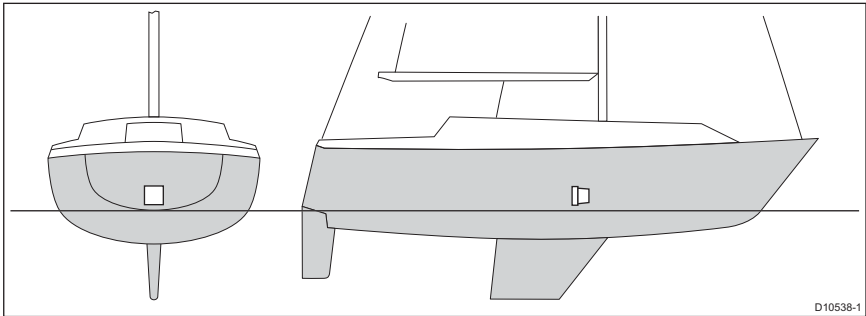

D10538-1

Note: To check if the intended mounting location is free from magnetic influence, tape a hand-held compass to the chosen location, then turn the boat through 360°. The readings on the hand-held compass and your boat's main steering compass (if accurately aligned) should not differ by more than 10° at any heading.

Mounting procedure

1. Mount the Fluxgate Compass on a vertical bulkhead, with the cable leaving at the bottom of the unit.
2. Stick the supplied warning label near to the compass, where it is clearly visible.

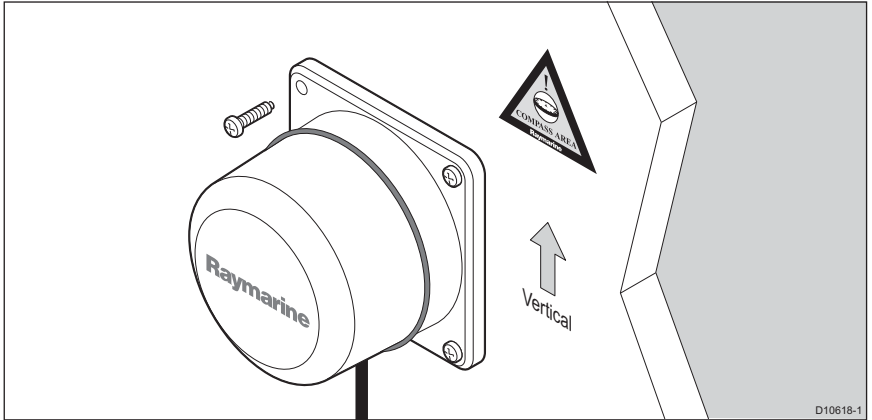

Compass connection

Route the compass cable to the Course Computer, securing it at regular intervals with suitable cable clips/ties.

Connect to the Course Computer as in the following illustration.

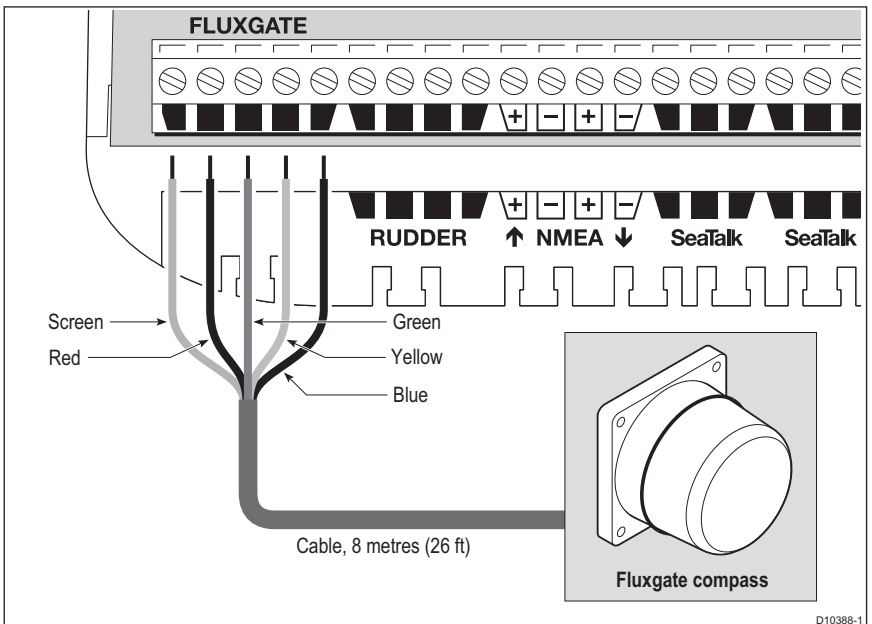

2.7 Pilot Controller

Fitting

The ST6002 Pilot Controller is supplied with an 9 m cable for connection to the SeaTalk bus. Ensure that your mounting location is within 9 m of a suitable connection point. You may purchase a longer cable if required.

Fit the controller in accordance with the separate instruction leaflet.

Connecting to SeaTalk

The Pilot Controller connects to SeaTalk at the Course Computer, as shown in following diagram.

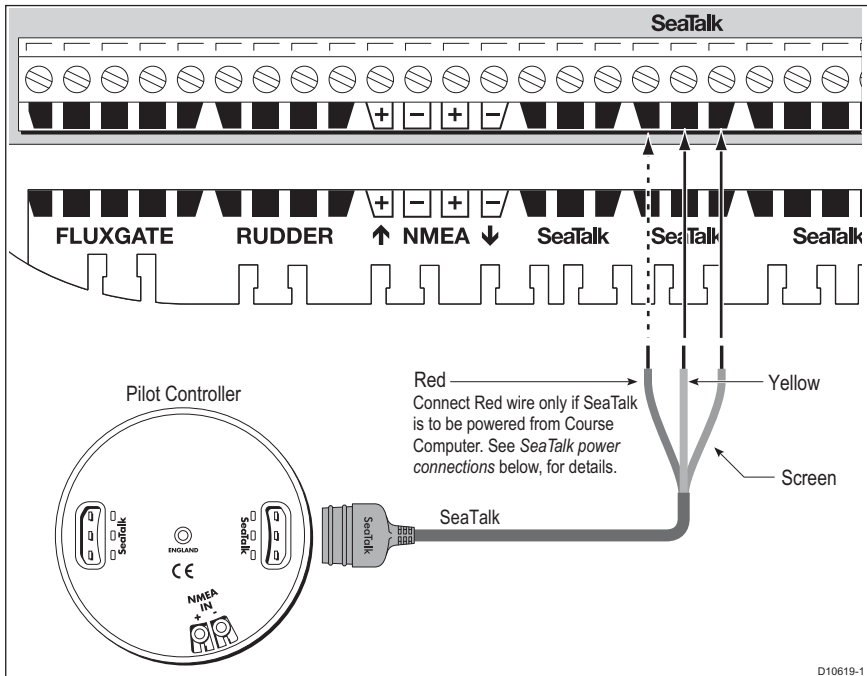

Note: *You will need an additional cable to connect your controller to an existing SeaTalk instrument*

SeaTalk power connections

The exact manner in which connections are made depends on how power is supplied to SeaTalk:

- If power is supplied by the Course Computer, connect the red and yellow wires and the screen to the Course Computer.
- If power is supplied from an external source, connect only the yellow wire and the screen to the Course Computer. Do NOT connect the red wire.

SeaTalk power supplied by Course Computer

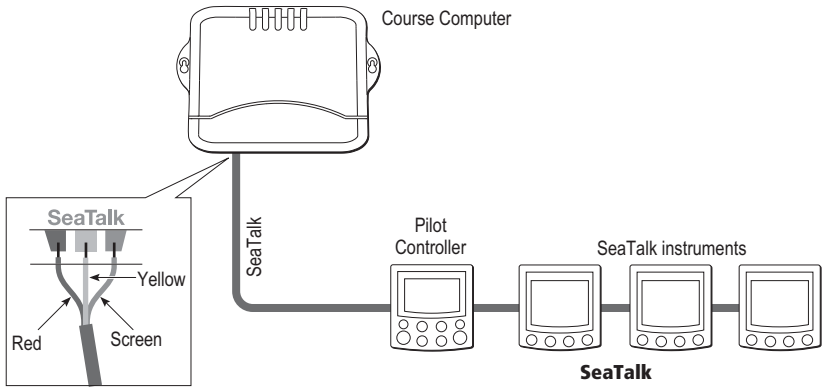

SeaTalk power supplied externally

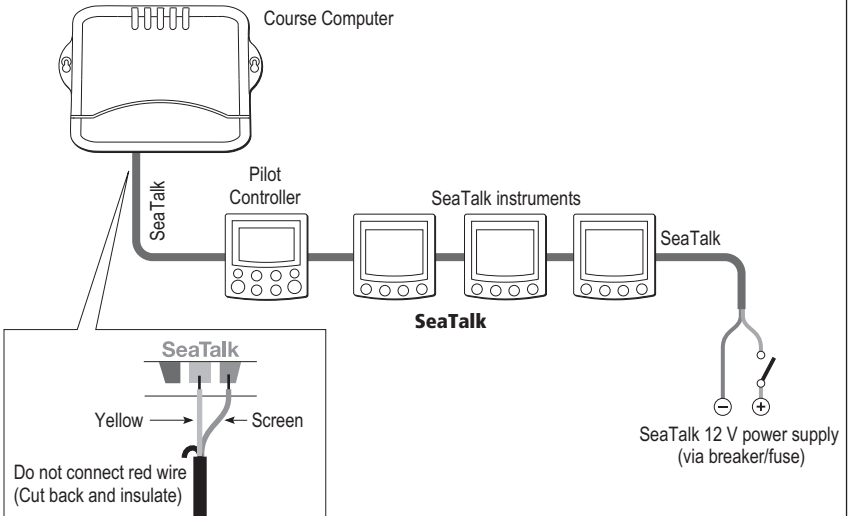

2.8 Connect to ground

CAUTION: Grounding

The SPX-5 Wheel system ground **MUST** be connected to ship's ground. Failure to connect to ship's ground may cause it, or other on-board electronics to malfunction.

To ground your SPX-5 Wheel system:

- Use a dedicated earthing plate (e.g. dynaplate) in contact with the water.
- Use flat tinned copper braid, 30 A rating (1/4 inch) or greater. Equivalent stranded wire diameter 4mm or greater
- Keep the length of the earth braid as short as possible.

Note: *If you cannot connect to a dedicated earthing plate you may connect ground to the negative terminal of the battery (ideally at the battery itself).*

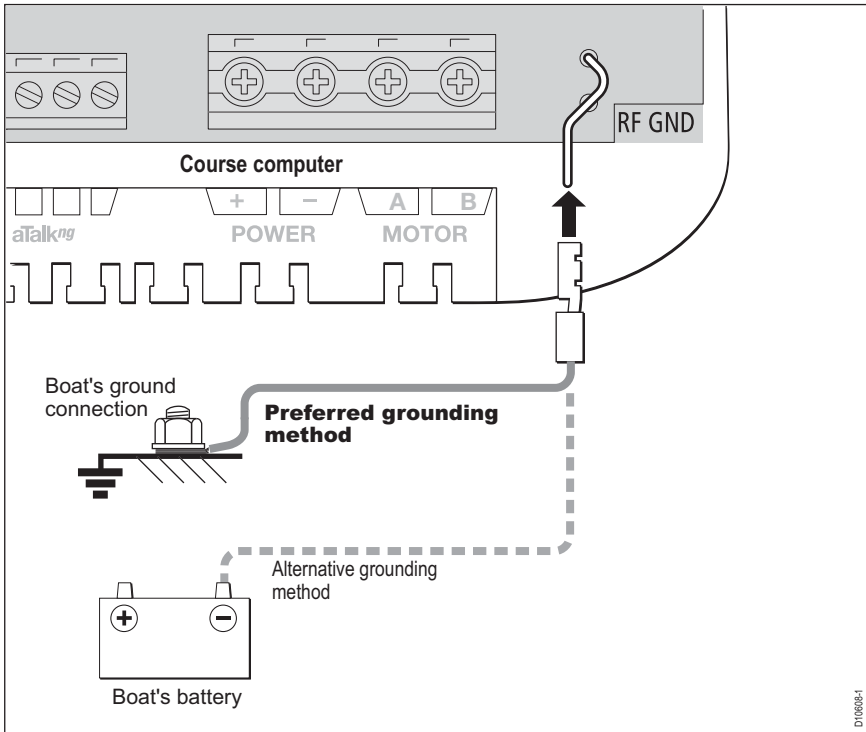

2.9 Optional connections

Rudder reference

An optional rudder reference transducer is available to provide an accurate display of the rudder angle. If you have the optional rudder reference transducer, connect it to the course computer as shown.

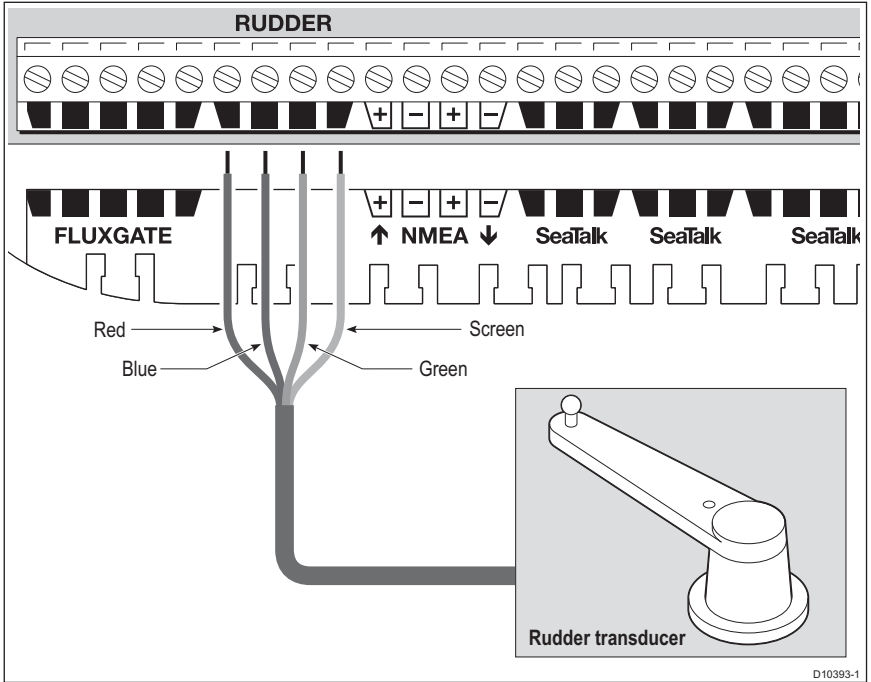

Note: A rudder reference transducer should always be used in hydraulic drive installations.

D10393-1

SeaTalk^{ng} Connections

To connect your autopilot to a SeaTalk^{ng} backbone, use a dedicated spur cable. Spur cables are available from your Raymarine dealer, as follows:

SeaTalk ^{ng} spur cable length	Part number
3 ft 3 in (1 m)	A06043
9 ft 10 in (3 m)	A06044

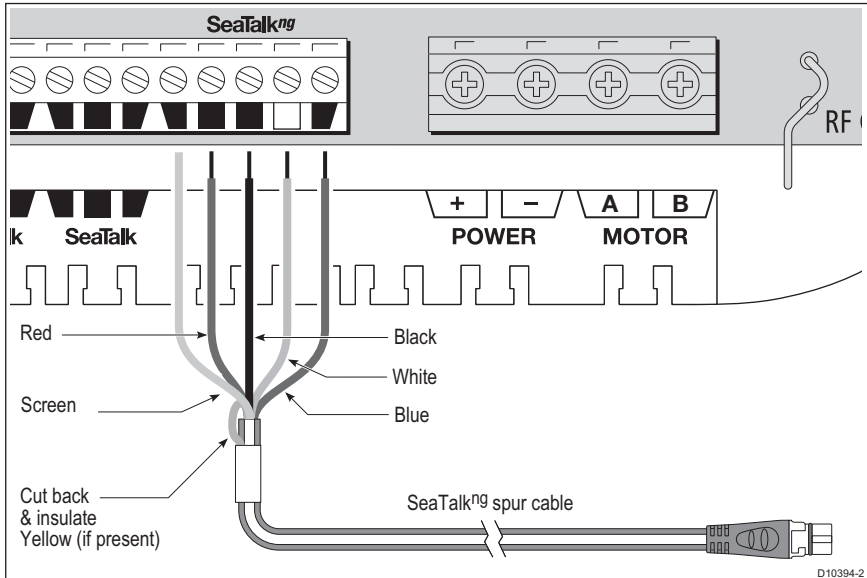

SeaTalk^{ng} power

The Course Computer does NOT supply power for SeaTalk^{ng}. A SeaTalk^{ng} system must be powered from its own separate power supply.

See also

For more information on SeaTalk^{ng} systems refer to the *SeaTalk^{ng} Reference Manual* available at the Raymarine website. www.raymarine.com/handbooks.

NMEA 0183 equipment

The SPX-5 Wheel system can connect to NMEA devices such as a GPS or chartplotter.

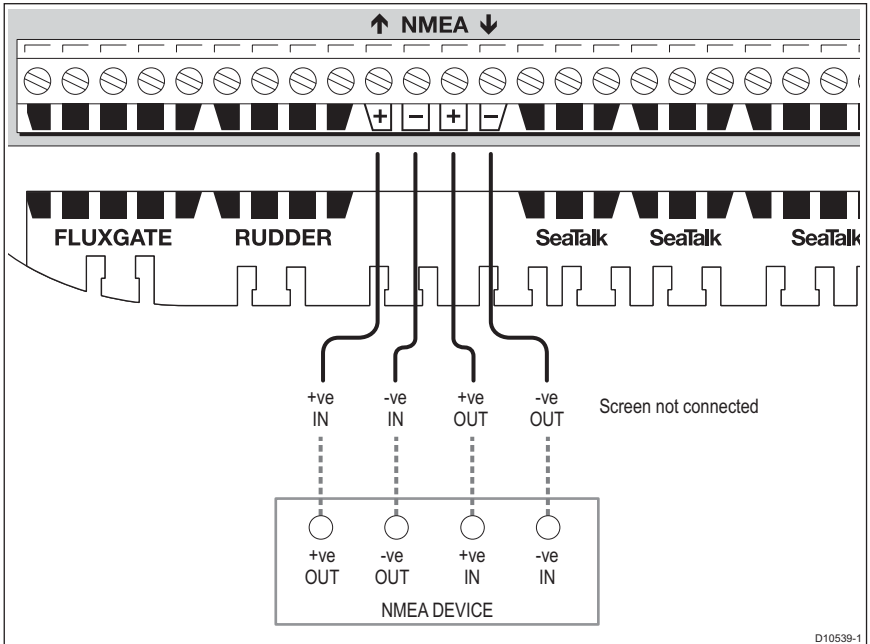

Data bridging

The SPX-5 Wheel system acts as a bridge between SeaTalk and NMEA, allowing NMEA and SeaTalk devices to share information.

For example, the information received from an NMEA GPS could be shared with a SeaTalk instrument to provide a separate Course Over Ground display.

NMEA 0183 / Connecting other manufacturers' equipment

- When connecting Raymarine equipment to other equipment using a non-Raymarine cable, you **MUST** attach an appropriate suppression ferrite to the cable near to the Raymarine unit.
- When connecting third party equipment refer to the manufacturer's instructions for cable details.
- You should not connect more than one piece of equipment to the Course Computer NMEA input.

2.10 Final checks

When you have completed all necessary installation procedures, but before you apply power to the system, ensure all equipment and connections are properly secured.

Secure all cables

To prevent strain on the connector blocks, secure the cables to the Course Computer with cable ties as shown below.

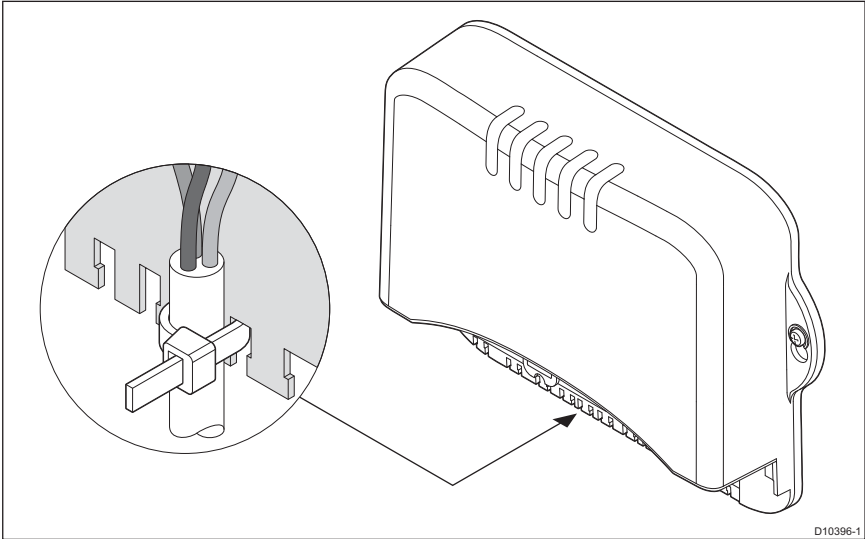

2.11 Commission the system before use

The SPX-5 Wheel system must be commissioned prior to use, in accordance with the instructions in *Chapter 3: Commissioning & setup*. For new systems this involves calibrating the system, which is a **safety-critical action**.

Chapter 3: Commissioning & setup

This chapter describes the commissioning and setup procedures for your Raymarine SPX-5 Wheel system.

Requirement

The commissioning procedures are mandatory and must be carried out after installation, before the SPX-5 Wheel system is used to steer the boat.

Additional setup procedures are also provided for you to fine tune your SPX-5 Wheel system for optimum performance with your boat. They are not mandatory and you may find that you do not need to use them if the SPX-5 Wheel system operates to your satisfaction after commissioning.

When commissioning and setting up the SPX-5 Wheel system, use the supplied ST6002 controller (Pilot Controller):

- standby & auto select the required operating mode.
- +1, -1, +10 & -10 initiate course changes.
- disp & track provide access to extended functions.

Note: *The system is also compatible with ST7002, ST8002 and ST70 Pilot Controllers*

3.1 Commissioning

The commissioning process comprises:

- Dockside checks & setup.
- Seatrial calibration.

Dockside checks & setup

The dockside checks comprise:

1. Switching on.
2. Checking SeaTalk and NMEA 0183 connections.
3. Checking autopilot steering sense.
4. Setting vessel type and drive type.
5. Setting rudder limits, if rudder reference option fitted.

With the boat safely tied up, carry out the dockside checks and setup procedures before any trials at sea or other setup procedures.

Switching on

1. Observing the Wheel drive unit, switch on the main power breaker. If the Wheel drive moves, switch off the power immediately, then ensure the system wiring is correct.
2. When the Pilot Controller and Course Computer are powered up, the controller will beep and show the controller type for a few seconds, before showing the **STANDBY** screen.
A **CALIBRATE REQUIRED** message may be displayed. This indicates that the autopilot commissioning is not yet complete.
3. Check that the **STANDBY** screen displays a live compass heading.

Note: *The autopilots built-in gyro requires a few minutes to stabilize after power on. During this time the heading may appear to drift until the gyro has stabilized.*

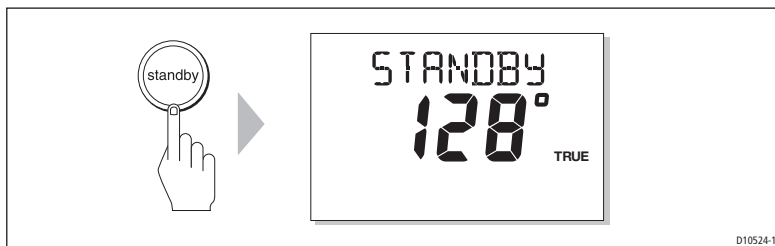

Checking SeaTalk and NMEA 0183 connections

SeaTalk instruments

If you have connected the Pilot Controller to other SeaTalk instruments or controllers:

1. Select display lighting level 3 (**LAMP 3**) on one of the other SeaTalk instruments or controllers.
2. Check that the Pilot Controller display lights are on. If the lights are not on, check the SeaTalk cabling between the Pilot Controller and the other units.

SeaTalk and NMEA GPS or Chartplotter

If you have connected the SPX-5 Wheel system to a chartplotter or GPS (e.g. via NMEA0183 or SeaTalk), check the links by displaying the default navigation data pages on the Pilot Controller. To do this:

1. Press **disp** to display the first data page (**XTE**), and check that this page shows the expected data.
2. Press **disp** again to check each successive data page (**BTW**, **DTW** etc)

If the display shows dashes in place of expected data values, ensure:

- The GPS or chartplotter is switched on and transmitting an active waypoint.
- The GPS or chartplotter is configured to transmit the required data format.
- There is not a cabling error. Check for open circuit, short circuit or reversed connections.

Other NMEA 0183 connections

To check other NMEA connections, you will need to set up the appropriate page of data using Display calibration mode. See *page 47*.

For details of supported NMEA sentences, see *Appendix 1: NMEA 0183 sentences*.

Checking autopilot operating sense



WARNING: Operate the **wheel drive clutch safely**

Do NOT reach through the wheel. Reach AROUND the wheel to operate the wheel drive clutch lever.

1. Engage the wheel drive clutch by reaching around the wheel and rotating the clutch lever clockwise, so the lever engages fully onto the locating pip.
2. Manually center the wheel, then press auto (so the SPX-5 Wheel system is in Auto mode), then check that the display shows **AUTO**.
Be ready to press standby if the rudder moves hard over.
3. Press +10 once.

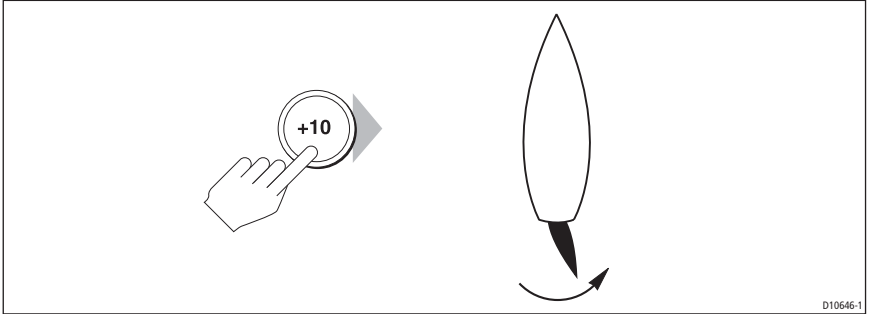

4. Check that the rudder moves to starboard a few degrees and then stops.
If the rudder drives hard over, immediately press standby to prevent further rudder movement.
5. If the rudder moves to port or the rudder drives hard over:
 - i. Press **standby**.
 - ii. Turn off the power.
 - iii. Reverse the motor wires connected to the SPX-5 Wheel system computer.
 - iv. Switch on the power and re-check.

Note: *If the rudder overshoots and has to drive back or starts to hunt back and forth, increase the rudder damping level manually (See page 54).*

Setting the vessel and drive type

To set up the vessel type and drive type, you need to enter the Dealer calibration mode.



WARNING: Use Dealer calibration correctly

Improper use of Dealer calibration can seriously impair the SPX-5 Wheel system performance and therefore adversely affect the steering capability. Do not change Dealer calibration settings other than as described in the product documentation.

To enter the Dealer calibration mode:

1. Ensure the autopilot is in Standby mode.
2. Hold down standby for two seconds to enter the Calibration mode.
3. When the screen shows **DISPLAY CAL**, press disp until the **DEALER CAL** screen is displayed.
4. Press auto. The display will change to **CAL?**.
5. Press **-1** and **+1** together to enter Dealer calibration.

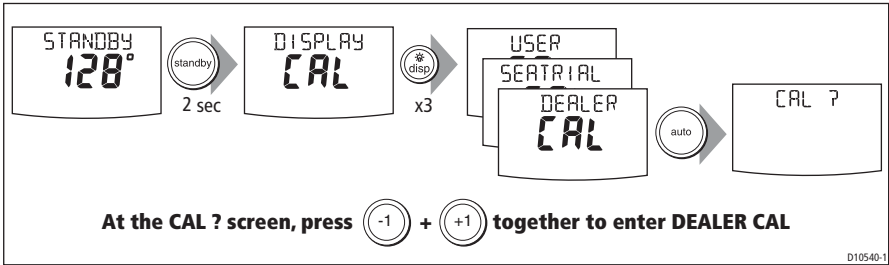

Set the vessel type

When you select a vessel type, the SPX-5 Wheel system automatically selects appropriate default values for various other calibration settings. These default values are listed on *page 57*.

To setup the vessel type, enter Dealer calibration then:

1. Use disp to scroll through the Dealer calibration pages until the display shows either **VESSEL** or one of the vessel types.
2. Use -1 or +1 to select **SAIL BOAT**:
3. Press disp to confirm the selection and move to the drive type option.

Set the drive type

1. With the SPX-5 Wheel system still in Dealer calibration, use disp to scroll through the calibration pages until you reach the **DRIVE TYP** page.
2. Use -1 or +1 to select drive type **3**.
3. Press disp to confirm the selection and move to the next calibration option.

Align the rudder indicator

Carry out this procedure only if the rudder reference option is fitted. If the rudder reference option is not fitted, ignore this procedure.

If the rudder reference option is fitted:

1. With the SmartPilot still in Dealer Calibration, press disp to scroll through the calibration pages until you reach the **ALIGN RUD** page.
2. Use the wheel to center the rudder.
3. Use -1 and +1 to adjust the rudder bar so it is positioned at the center.
The maximum adjustment available is $\pm 9^\circ$. If the offset is beyond these limits, you will need to physically adjust the alignment of the sensor.
4. Press disp to confirm the correct alignment and move to the next calibration option.

Note: *Alternatively, you can zero the rudder bar with the boat underway during the initial seatrial, by manually steering a straight course then accessing the **ALIGN RUD** screen in Seatrial Calibration to adjust the offset.*

Set the rudder limits

Carry out this procedure only if the rudder reference option is fitted. If the rudder reference option is not fitted, ignore this procedure.

If the rudder reference option is fitted:

1. With the SmartPilot still in Dealer Calibration press disp to scroll through the calibration pages until you reach the **RUD LIMIT** page.
2. Turn the wheel to move the rudder:
 - To the port end stop and note the angle on the rudder bar
 - To the starboard end stop and note the angle on the rudder bar
3. Use -1, +1, -10 and +10 to set the rudder limit to 5° less than the lowest angle you have noted.
4. Press disp to select the new value and move to the next calibration option.

Save the new settings

When you have adjusted the above settings, hold down standby for two seconds, to save your changes, leave Dealer calibration and return to the Standby mode.

Seatrial calibration

When you have completed the dockside checks, carry out a Seatrial calibration, to calibrate the compass and set up the autopilot steering characteristics.

Before commencing the seatrial:

- The dockside calibration must have been successfully completed.
- There must be no EMC problems (see *page 7*).

Important

If you need to return to manual steering at any time during a Seatrial or any other procedure, **press the standby button**. NEVER compromise vessel safety.

Seatrial conditions

The seatrial must be carried out only:

- In conditions of light wind and calm water.
- In waters that are clear of any obstructions, so the boat has plenty of clear space to maneuver.

In order to achieve optimum autopilot performance, course over ground (COG), speed over ground (SOG) and latitude (LAT) data must be available to the SPX-5 Wheel system (e.g. on SeaTalk). Ensure that the equipment providing this information (e.g. GPS), is switched on and fully operational, before starting a Seatrial.

The Seatrial procedures are:

- Compass calibration.
- Using AutoLearn to set the SPX-5 Wheel system steering characteristics.

Compass calibration

The compass calibration procedures are:

- Swinging the compass.
- Aligning the compass.

Swinging the compass

The magnetic deviation correction procedure (commonly called “swinging the compass”) involves turning your boat in slow circles so the autopilot can automatically

determine the deviation and apply any correction required. The correction procedure reduces deviation errors to a few degrees.

As magnetic deviation can cause significant compass errors on your boat, you **MUST** complete the compass swing before any other seatrial procedure.

To swing the compass:

1. With the pilot in Standby mode, enter Seatrial calibration as follows:
 - i. Hold down standby for two seconds to enter Calibration mode.
 - ii. When you see the **DISPLAY CAL** screen, press disp until you see the **SEATRIAL CAL** screen.
 - iii. Press auto to enter Seatrial calibration.
2. Use disp to move through the Seatrial calibration items until you see **SWING COMPASS**.

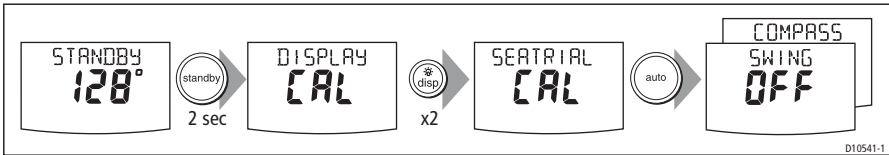

Note: If you cannot access Seatrial calibration, you need to disable the calibration lock. This can be found in Dealer calibration (see page 52).

3. When you are ready to start, press +1, to select **SWING COMPASS ON**.
4. Press auto to start the compass swing.
The Pilot Controller will display **TURN BOAT**.
5. Start slowly turning the boat in circles (keeping the boat's speed below 2 knots). You will need to complete at least two circles, taking at least 2 minutes to complete each 360°:

If you turn the boat too quickly, the display will show a **TOO FAST** message. If this occurs, **apply less helm to turn in a larger circle**.

Note: If necessary, you can quit the correction process by pressing **standby** or **disp**. If you then want to repeat the deviation correction, return to the **SWING COMPASS** screen.

6. Continue slowly turning the boat until the controller beeps and displays the **DEVIATION** screen. This indicates that the SPX-5 Wheel system has completed the deviation correction.

Note: This screen shows the maximum deviation encountered over 360° (not as an east/west value).

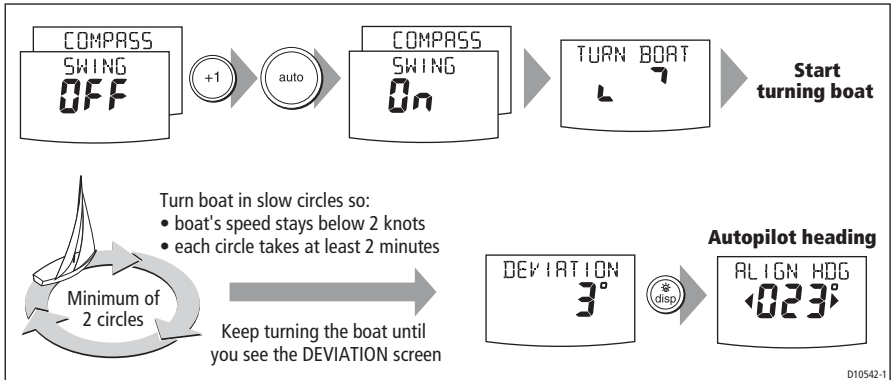

If the deviation figure exceeds 15° or the display shows no deviation value, the compass is being affected by ferrous objects on your boat. You should move the compass to a better location. Higher deviation figures are acceptable on steel boats.

Aligning the compass heading

Once the deviation is displayed, press disp to move to the Heading Alignment (**ALIGN HDG**) page, then:

1. Manually steer the boat on a steady course at a speed sufficient to hold the course.
2. If you have a GPS connected to your SPX-5 Wheel system:
 - i. Increase the boat speed to more than 3 knots.
 - ii. Press auto. The SPX-5 Wheel system will then set the heading to agree with the COG (course over ground) heading received from the GPS.

As many factors can cause a difference between heading and COG you must fine-tune the heading alignment so it matches the boat's steering compass (or a known transit bearing). To do this:

1. Use -1, +1, -10 and +10 to adjust the displayed heading until it matches boat's steering compass (or a known transit bearing).
2. Hold down standby for 2 seconds to exit Seatrial calibration and save the new compass settings.

Align the autopilot heading

- a) Coarse adjustment:** If COG is available from GPS, press  to set autopilot heading to COG value, then fine tune manually (see below).
- b) Fine adjustment:** If COG is not available (or after setting heading to COG), align autopilot heading manually:

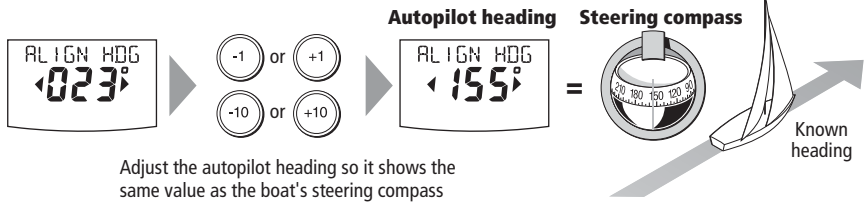

Save changes



- To:
- save deviation correction
 - save heading alignment
 - return to STANDBY mode

D10543-1

Although the compass calibration removes most of the alignment error, small errors (a few degrees) may remain. Once you have completed the initial compass calibration, you can make further adjustments to the alignment without having to swing the compass again.

Check the heading reading against a number of known headings, plot a deviation curve, and determine the heading alignment value that will give the lowest **average** alignment error. You can then enter this value on the Heading Alignment screen, as described above.

If the average heading error is more than 5°, you should perform the compass deviation correction procedure again, circling more slowly and in more favorable conditions.

AutoLearn



WARNING: Ensure there is enough clear sea space

The AutoLearn process takes the boat through a number of maneuvers, which can result in sudden, sharp turns, especially when the AutoLearn function is run on more maneuverable boats. Therefore, ensure there is a significant amount of CLEAR SEA SPACE in front of the boat, before starting an AutoLearn process.

The next stage of the Seatrial is to carry out an AutoLearn routine. AutoLearn is a self-learning calibration feature that automatically adjusts rudder gain, counter rudder and AutoTrim for optimum performance for your boat.

If you need to return to manual steering at any time during an AutoLearn routine or any other procedure, **press the standby button**. NEVER compromise vessel safety.

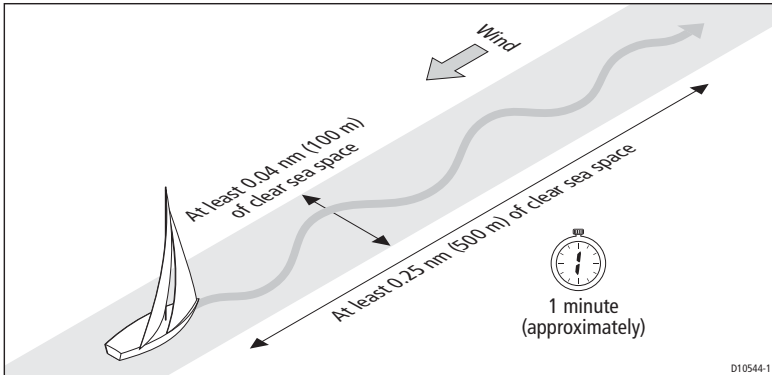

Carry out an AutoLearn as follows:

1. Ensure you have sufficient sea room to complete the AutoLearn:
2. Access the **AUTOLEARN** screen in Seatrial calibration as follows:
 - i. From Standby mode, hold down standby for 2 seconds, then press disp twice to see the SEATRIAL CAL screen.
 - ii. Press auto to enter Seatrial calibration, then press disp four times to see the **AUTOLEARN** screen.
3. Prepare to start the AutoLearn as follows:
 - Steer straight ahead (rudder centered) and motor the boat at typical cruising speed.
 - If conditions are not calm, head into the wind and waves.
4. When you are ready to start the AutoLearn, press +1 then auto.

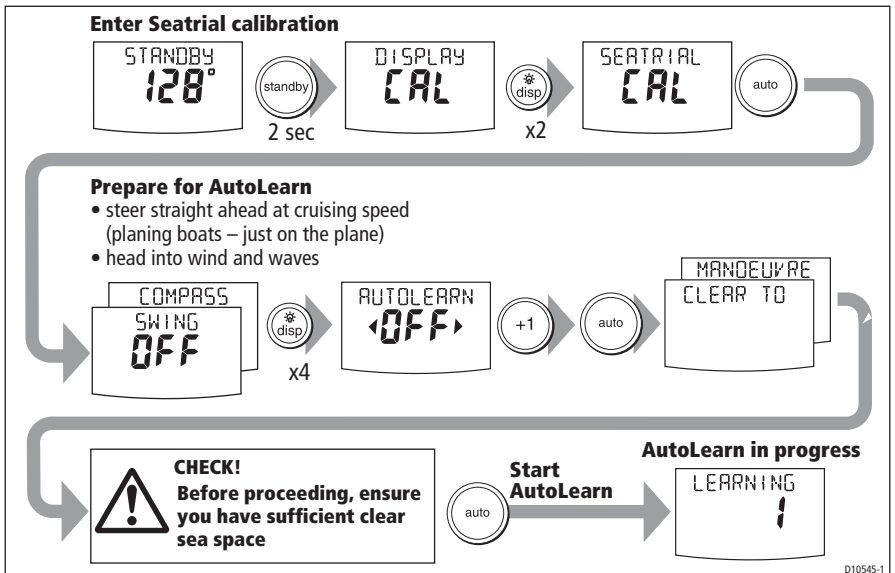

5. The screen will show the **CLEAR TO MANEUVER** message. Ensure it is safe to continue, then press **auto** to start the AutoLearn maneuvers:
 - The boat will start a series of zig-zag turns and the display will show **LEARNING** with a number to indicate the current AutoLearn stage. This number increases as AutoLearn progresses.
 - A typical AutoLearn completes within 7 to 27 steps (depending on boat characteristics and sea conditions).

Note: To cancel an AutoLearn, press **standby** or **disp**.

6. When the SPX-5 Wheel system has finished learning, the controller will beep and display either **LRN PASS** or **LRN FAIL**:
 - **LRN PASS** = AutoLearn completed successfully
 - **LRN FAIL** = AutoLearn was not successful, so should be repeated. One of the following failure codes will also be displayed:
 - 1 = AutoLearn has not been carried out.
 - 2 = AutoLearn failed, due to manual interruption.
 - 4 = AutoLearn failed, probably due to drive or compass failure.
 - 5 = AutoLearn failed, probably due to motor current limiting.
 - 6 = AutoLearn failed, probably due to boat spinning.
7. If the AutoLearn was successful, hold down **standby** for 2 seconds to store the new settings.

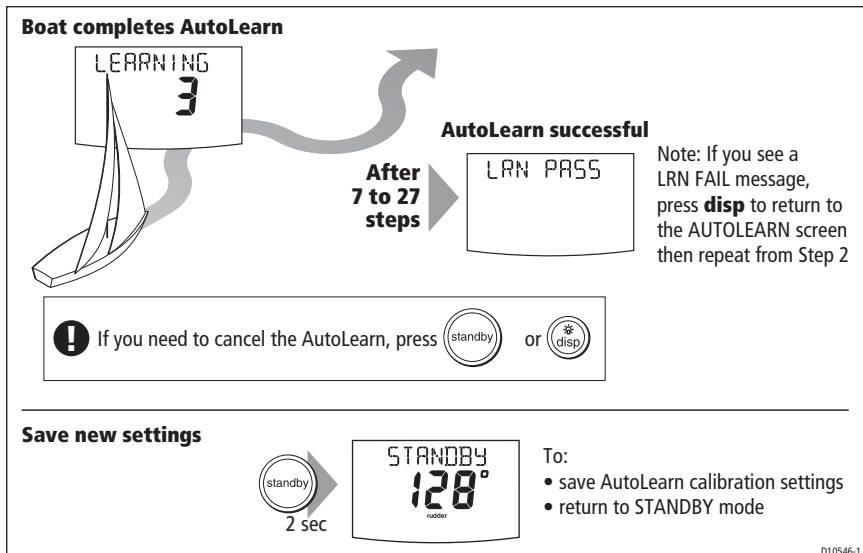

Commissioning complete

Your SPX-5 Wheel system is now commissioned and ready for use.

After having used your SPX-5 Wheel system, you may decide to change the value of some parameters to improve pilot performance with your boat. If you feel this is necessary, use the appropriate procedures under *Manual setup*, below.

3.2 Manual setup

Checking SPX-5 Wheel system operation

Before manually adjusting any settings, familiarize yourself with basic SPX-5 Wheel system operation, as follows:

1. Steer onto a compass heading and hold the course steady at a normal cruising speed. If necessary, steer the boat manually for a short time to check how the boat steers.
2. Press auto to lock onto the current heading. The SPX-5 Wheel system should hold the locked heading in calm sea conditions.
3. Use -1, +1, -10 and +10 and observe how the SPX-5 Wheel system alters the course to port and starboard.
4. Press **standby** to return to manual steering.

If you feel you need to fine tune the SPX-5 Wheel system performance, you can do so by using one or more of the procedures below to adjust:

- Response level.
- Rudder gain.
- Counter rudder.
- AutoTrim.

Over time you may wish to repeat these adjustments using a range of sea conditions and headings to achieve optimum all-round performance for your particular vessel and preferences.

Adjust these settings when motoring your boat at cruising speed.

Response level

The principal method of adjusting the performance of an SPX-5 Wheel system is by changing the response level. This controls the relationship between the SPX-5 Wheel system's course keeping accuracy and the amount of helm/drive activity.

Screen Text	Effect on operation
RESPONSE 1-3	This setting minimizes the amount of rudder activity but may compromise short-term course keeping accuracy,
RESPONSE 4-6	This setting gives good course keeping with crisp, well controlled turns under normal operating conditions.
RESPONSE 7-9	This setting provides the tightest possible course keeping and greatest rudder activity. This can lead to a rough passage in open waters as the SPX-5 Wheel system may fight the sea.

To **temporarily** change the response level:

1. Press -1 and +1 or resp to access the RESPONSE screen.
2. Use -1 or +1 to adjust the setting.
3. Press disp to confirm the change.

Rudder gain

Boats can vary widely in their response to helm, and by adjusting the rudder gain you can change the SPX-5 Wheel system's steering characteristics. Rudder gain is a measure of how much helm the SPX-5 Wheel system applies to correct course errors – higher settings mean more rudder is applied.

Checking

Complete the following test to determine whether the rudder gain is set correctly:

1. Set **RESPONSE** to level 5 (see above).
2. Motor your boat at a typical cruising speed in clear water. (It is easier to recognize the steering response in calm sea conditions where wave action does not mask steering performance.)
3. Press auto to enter Auto mode, then alter course by 40°:
 - If the rudder gain is adjusted correctly, the 40° course change should result in a crisp turn followed by an overshoot of no more than 5°.
 - If the rudder gain setting is too high, the 40° course change will result in a distinct overshoot of more than 5° and there may be a distinct 'S' in the course, as at **(A)** below.
Correct this oversteer by **reducing** the rudder gain setting.
 - If the rudder gain is too low, the boat's performance will be sluggish – it will take a long time to make the 40° turn and there will be no overshoot (**B** below).
Correct this understeer by **increasing** the rudder gain setting.

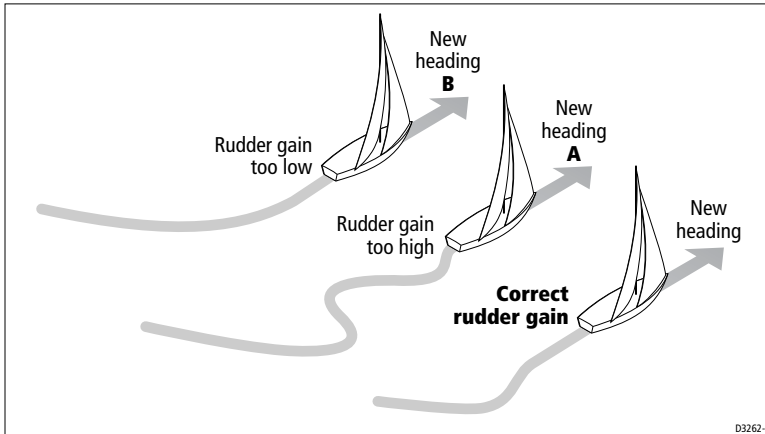

Adjusting

To adjust the rudder gain:

1. Access the **RUDD GAIN** screen in Dealer calibration (see *page 53*).
2. Use -1 or +1 to adjust the rudder gain.
3. Hold down standby for 2 seconds to save the changes.
4. Press auto to check the SPX-5 Wheel system performance in Auto mode.

Counter rudder

Counter rudder is the amount of rudder the SPX-5 Wheel system applies to try to prevent the boat from yawing off course. Higher counter rudder settings result in more rudder being applied.

Checking

To check the counter rudder setting:

1. Set **RESPONSE** to level **5** (see *page 41*).
2. Motor your boat at cruising speed in clear water.
3. Press auto to switch the SPX-5 Wheel system to Auto mode, then make a 90° course change:
 - When gain and counter rudder are both set correctly, the boat performs a smooth continuous turn with minimal overshoot.
 - If the counter rudder is too low, the boat will still overshoot.
 - If counter rudder is too high, the boat will 'fight the turn' and make a series of short, sharp turns: this results in a very 'mechanical' feel as the boat changes course.

Adjusting

To adjust the counter rudder:

1. Access the **COUNT RUD** screen in Dealer calibration. (see *page 53*)
2. Use -1 or +1 to adjust the counter rudder.
3. Press and hold standby for 2 seconds to save the changes.
4. Press auto to check the SPX-5 Wheel system performance in Auto mode.

AutoTrim

You may also wish to adjust the AutoTrim setting. AutoTrim determines how quickly the SPX-5 Wheel system applies 'standing helm' to correct for trim changes, caused, for example, by changes in the wind load on the superstructure, or an imbalance of engines.

Increasing the AutoTrim level reduces the time the SPX-5 Wheel system takes to get back onto the correct course, but makes the boat less stable. If the SPX-5 Wheel system:

- Gives unstable course keeping and the boat 'snakes' around the desired course, **decrease** the AutoTrim level.
- Hangs off course for excessive periods of time, **increase** the AutoTrim level.

Adjusting

Before attempting to adjust the AutoTrim setting, ensure you have sufficient experience using your SPX-5 Wheel system.

If you need to adjust AutoTrim, go up one level at a time and use the lowest acceptable value. The range of settings is from **OFF** (no trim correction) to **4** (fastest trim correction).

To adjust the AutoTrim

1. Access the **AUTOTRIM** screen in Dealer calibration mode, then:
2. Use -1 or +1 to adjust the AutoTrim level.
3. Hold down standby for 2 seconds to save the changes.
4. Press auto to check the SPX-5 Wheel system performance in Auto mode.

Chapter 4: SPX-5 Wheel system settings

4.1 Introduction

This chapter describes the SPX-5 Wheel system calibration settings and the factory default settings. The calibration settings can be adjusted to best suit your operating requirements, but as many will have been adjusted to optimum values when commissioning the system, they should not require further change.

If you change the calibration settings after the SPX-5 Wheel system has been commissioned, you do not need to repeat the commissioning process. However, DO NOT manually adjust autopilot settings before the commissioning procedures in *Chapter 3* have been completed.

Calibration modes

There are four calibration modes, namely Display calibration, User calibration, Seatrial calibration and Dealer calibration.

Each calibration mode uses a series of screens to set calibration values.

Display calibration

The items in Display calibration affect the SPX-5 Wheel system Pilot Controller. They are stored in the controller and do not affect any other controllers connected through SeaTalk.

You can adjust the Display calibration settings as often as necessary – for example, to add or change information displayed on data pages.

User calibration

The User calibration mode includes settings that you may need to adjust on a regular basis to respond to changing conditions.

Seatrial calibration

The Seatrial calibration mode is used ONLY when commissioning your SPX-5 Wheel system, as described in *Chapter 3*, so is not described again here. **Do not access Seatrial calibration during normal operation.**

Dealer calibration

The Dealer calibration mode includes items that have a significant impact on operation and can affect your boat's safety.

After you have completed the initial installation and seatrial, you should not normally need to alter the Dealer calibration values.

Accessing the Calibration modes

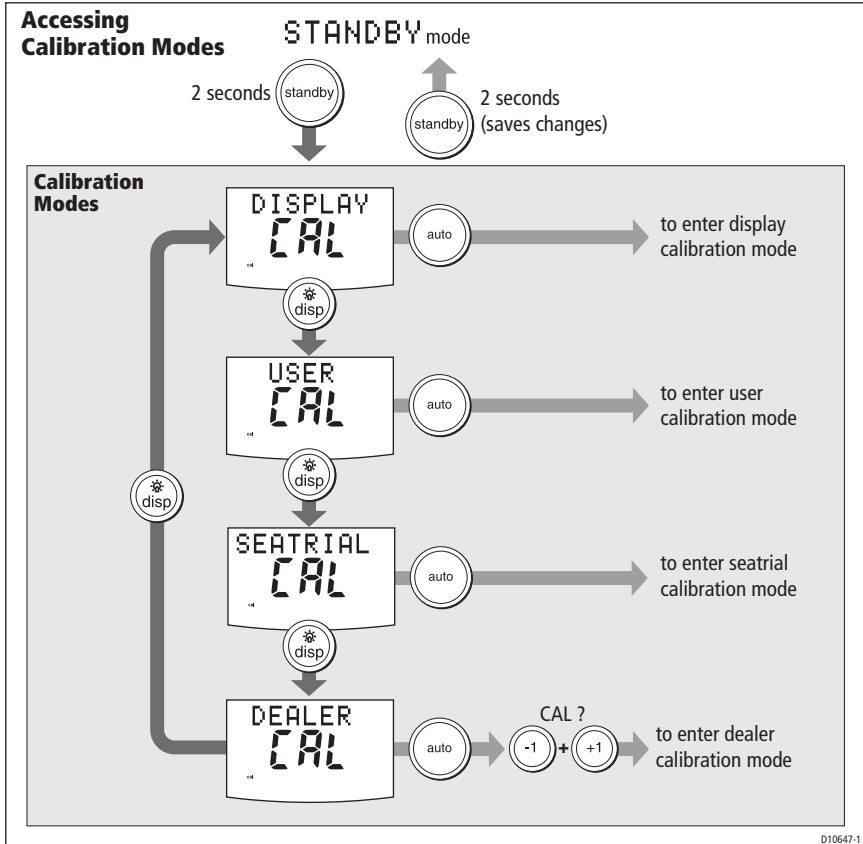

Adjusting calibration values

To adjust calibration values:

1. Access the required calibration mode (refer to the diagram above).
2. Press disp to scroll through the available options. To view the previous option, press and hold disp for 1 second.
3. Use -1, +1, -10 and +10 to change the values.

When you have made all required changes, press and hold standby for 2 seconds to save changes and exit.

4.2 Display calibration

Display calibration provides settings to adjust the information displayed on the Pilot Controller.

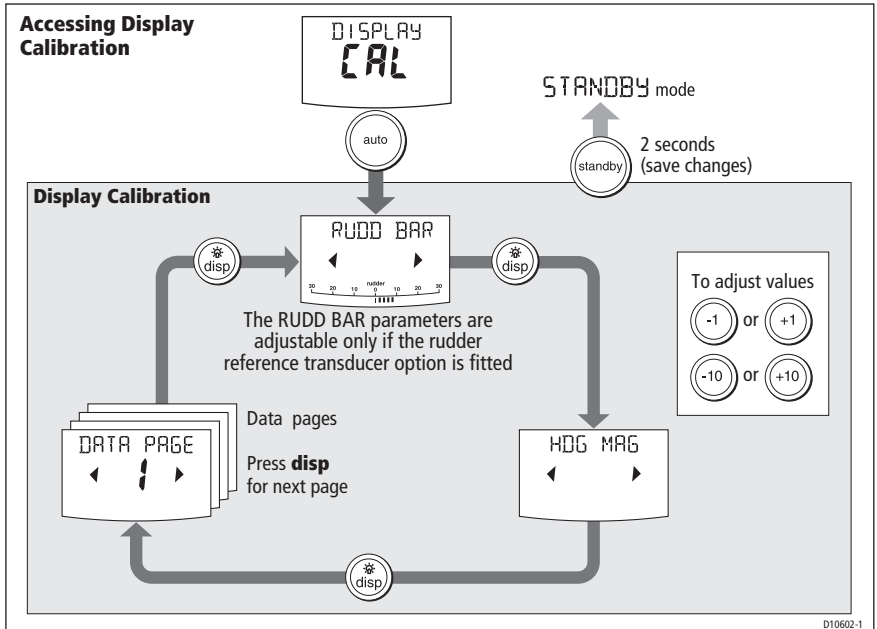

RUDD BAR screen

This screen gives you access to the other Display calibration screens.

HDG screen

You can choose whether to use magnetic or true heading data values. The options are:

- **HDG MAG** - Magnetic heading. If you select this, the screen will indicate **MAG** for heading values, during normal operation.
- **HDG TRUE** - True heading. If you select this the screen will indicate **TRUE** for heading values, during normal operation.

Data pages

The Pilot Controller has fifteen user-configurable data pages. Each data page can be configured to display SeaTalk/NMEA data, which can be viewed during normal operation (see *SmartPilot-X5 Wheel system Operating Guide*).

The default data page settings are:

Data Page	Default Setting
1	XTE (Cross Track Error)
2	BTW (Bearing to Waypoint) - see Note below
3	DTW (Distance to Waypoint) - see Note below
4	RESPONSE
Remaining pages	NOT USED (see <i>Setting up data pages</i> below)

Setting up data pages

When setting up your data pages, we recommend:

- You set data pages you do not need to **NOT USED**, as these will then not be displayed during normal operation, leaving just the data pages that you do want for you to scroll to.
- You retain the **BTW** and **DTW** data pages. If your SPX-5 Wheel system receives a man overboard (MOB) message, these data pages will show the bearing and distance to the MOB location.

Available Data Pages	Displayed as
Speed Knots	SPEED KTS
Log	LOG XXXX.X
Trip	TRIP XXX.X
Average Speed	AV. SPD
Wind Direction	e.g. WIND PORT
Wind Speed	WIND KTS
Depth Metres	DEPTH M - see Note below
Depth Feet	DEPTH FT - see Note below
Depth Fathoms	DEPTH FA - see Note below
Heading	HEADING
Water Temperature, Degrees C	WATER °C - see Note below
Water Temperature, Degrees F	WATER °F - see Note below
Course Over Ground	COG
Speed Over Ground, Knots	SOG KTS
Cross Track Error	XTE
Distance to Waypoint	DTW

Available Data Pages	Displayed as
Bearing to Waypoint	BTW
Rudder Gain	RUDD GAIN
Response	RESPONSE
Watch	WATCH - used to control the Watch timer
Universal Time Coordinated	UTC

Note: *There are 3 depth data pages (meters, feet and fathoms) and 2 water temperature data pages (°C and °F). The SPX-5 Wheel system will display the depth data or water temperature in the units defined by the data page you select.*

4.3 User calibration

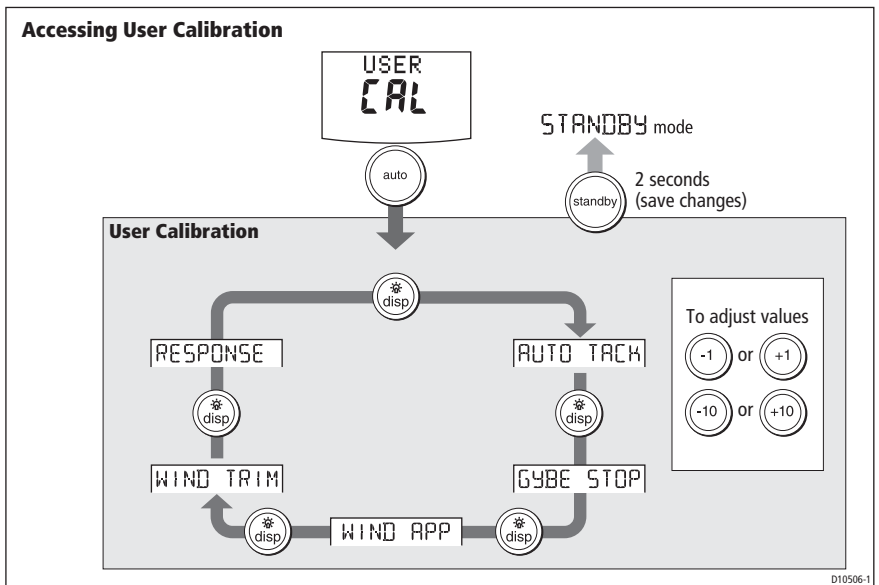

For information on how to access User calibration, see *Accessing the Calibration modes*, page 46.

The User calibration mode includes settings that you may need to adjust on a regular basis to respond to changing conditions.

AutoTack

The AutoTack angle is not adjustable. The apparent wind angle when AutoTack is initiated, is mirrored the other side of the wind, on the opposite tack.

Gybe inhibit

With gybe inhibit on:

- You will be able to perform an AutoTack into the wind.
- The SPX-5 Wheel system will prevent the boat from performing an AutoTack away from the wind, to prevent accidental gybes.

With gybe inhibit off, you can perform an AutoTack into or away from the wind.

Screen Text	Options
GYBE STOP	ON (Default) = Gybe inhibit on (gybes prevented) OFF = Gybe inhibit off (gybes permitted)

Wind selection

This screen determines whether the boat steers to apparent or true wind in Wind Vane mode.

Options	
WIND APP (Default)	SPX-5 Wheel system steers to apparent wind angle
WIND TRUE	SPX-5 Wheel system steers to true wind angle

WindTrim

WindTrim controls how quickly the SPX-5 Wheel system responds to changes in the wind direction. Higher wind trim settings will result in a system that is more responsive to wind changes.

Screen Text	Options
WIND TRIM	Range = 1 to 9 1 to 3 - Least responsive to wind changes (less system activity) 4 to 6 - Moderate response to wind changes 7 to 9 - Most responsive to wind changes (more system activity)

Response level

This sets the default SPX-5 Wheel system response level. The response level controls the relationship between course keeping accuracy and the amount of helm/drive activity. You can make temporary changes to response during normal operation, as described in *Smart Pilot X-5 Wheel System Operating Guide*.

Screen Text	Options
RESPONSE	Range = 1 to 9 Level 1 to 3 minimizes the amount of pilot activity. This conserves power, but may compromise short-term course-keeping accuracy. Level 4 to 6 should give good course keeping with crisp, well controlled turns under normal operating conditions Level 7 to 9 gives the tightest course keeping and greatest rudder activity (and power consumption). This can lead to a rough passage in open waters as the SPX-5 Wheel system may 'fight' the sea.

4.4 Dealer calibration

For information on how to access Dealer calibration, see *Accessing the Calibration modes, page 46*.



WARNING: Dealer calibration

Changing the Dealer calibration values can have a significant affect on the SPX-5 Wheel system steering characteristics and therefore on the safety of your boat.

Some Dealer calibration values are adjusted during the commissioning process (see *Chapter 2: Commissioning & setup*), and once the SPX-5 Wheel system has been commissioned you should not normally need to change Dealer calibration values.

However if you decide you want to change values in Dealer calibration, be aware that the Dealer calibration mode includes items that have a **significant impact on SPX-5 Wheel system operation and can affect your boat's safety**.

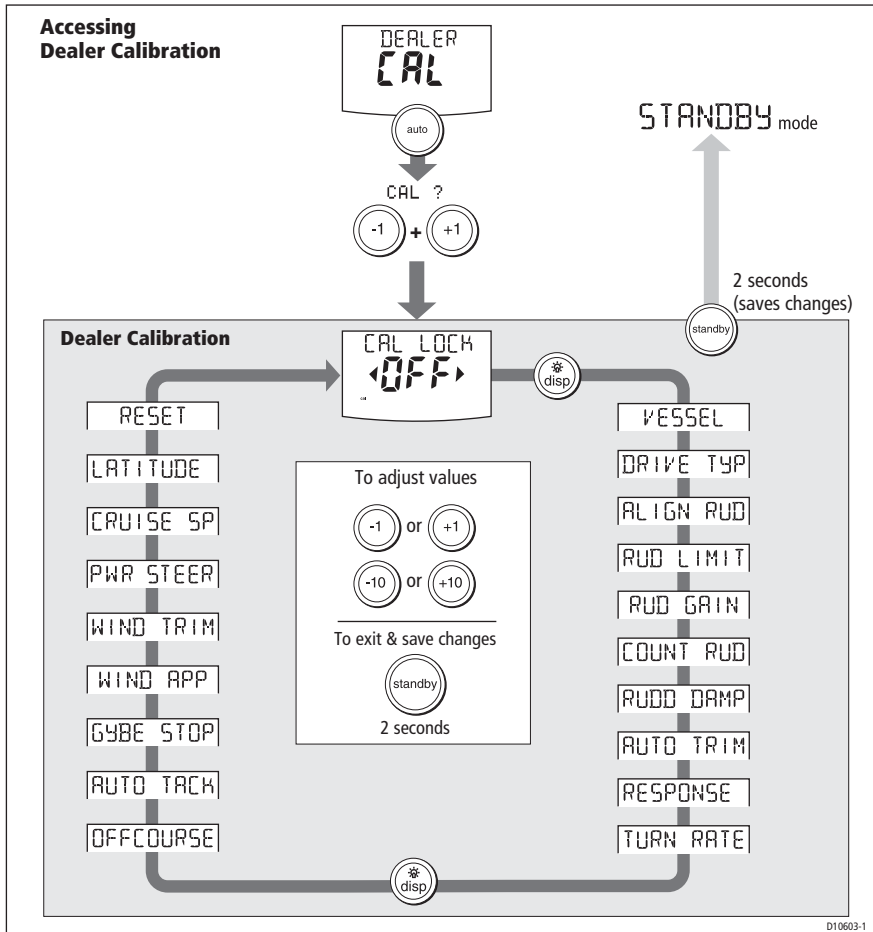

Seatrial calibration lock

This screen controls the access to Seatrial calibration.

Screen text	Options
CAL LOCK OFF	Calibration lock off – Seatrial calibration can be accessed (default)
CAL LOCK ON	Calibration lock on – Seatrial calibration cannot be accessed

Vessel type

Selecting the correct vessel type, enables the SPX-5 Wheel system to set appropriate values for other calibration settings, to give optimum performance. Refer to the table on *page 57* for default values.

The correct setting for the SPX-5 Wheel system is **SAIL BOAT**. This should be set when commissioning the SPX-5 Wheel system.

Drive type

The drive type setting controls how the SPX-5 Wheel system drives the steering system.

The correct setting for the SPX-5 Wheel system is **3**. This should be set when commissioning the SPX-5 Wheel system.

Align rudder

The align rudder screen is displayed only if the rudder reference option is fitted.

If the rudder reference option is fitted, use this screen is used to calibrate the rudder bar display. This should be set when commissioning the SPX-5 Wheel system (see *page 31*).

Screen Text	Range
ALIGN RUD	-9° to +9° in 1° steps

Rudder limit

The rudder limit screen is displayed only if the rudder reference option is fitted.

If the rudder reference option is fitted, this screen is used to set the limits of the rudder control just inside the mechanical end stops, and thus avoid putting the steering system under unnecessary load. This should be set when commissioning the SPX-5 Wheel system (see *page 31*).

Screen Text	Range
RUD LIMIT	10° to 40° in 1° steps

Rudder gain

Rudder gain is a measure of how much helm the SPX-5 Wheel system applies to correct course errors. The higher the setting the more rudder will be applied.

The rudder gain setting is set automatically as part of the AutoLearn process (see *page 42*).

Screen Text	Range
RUDD GAIN	1 to 9

Counter rudder

Counter rudder is the amount of rudder the SPX-5 Wheel system applies to try to prevent the boat from yawing off course. Higher counter rudder settings result in more rudder being applied.

The default counter rudder gain is set as part of the initial seatrial AutoLearn process (see *page 43*).

Screen Text	Range
COUNT RUD	1 to 9 (Do NOT set to 0)

Rudder damping

If the SPX-5 Wheel system 'hunts' when trying to position the rudder, adjust the rudder damping value to minimize this. Increasing the rudder damping value reduces hunting. Increase the damping one level at a time until the autopilot stops hunting, and always use the lowest acceptable value.

Screen Text	Range
RUDD DAMP	1 to 9

AutoTrim

The AutoTrim setting determines the rate at which the SPX-5 Wheel system applies 'standing helm' to correct for trim changes caused by varying wind loads on the sails or superstructure.

The default AutoTrim is set as part of the AutoLearn process (see *page 43*).

If you need to change the setting, increase the AutoTrim one level at a time and use the **lowest** acceptable value:

- If the SPX-5 Wheel system gives unstable course keeping or excessive drive activity with a change in the heel angle, decrease the AutoTrim level.
- If the SPX-5 Wheel system reacts slowly to a heading change due to a change in the heel angle, increase the AutoTrim level.
- If the AutoTrim level is too high, the boat will be less stable and snake around the desired course.

Setting	Effect
AUTO TRIM OFF	No trim correction
AUTO TRIM 1 to 4	Auto trim applied: 1 = Slowest, 4 = Fastest

Response level

This sets the default SPX-5 Wheel system response level setting. The response level controls the relationship between course keeping accuracy and the amount of helm/drive activity. You can make temporary changes to response during normal operation (see your *Operating Guide* for details).

Screen Text	Options
RESPONSE	Range = 1 to 9 Level 1 to 3 minimizes the amount of pilot activity. This conserves power, but may compromise short-term course-keeping accuracy Level 4 to 6 should give good course keeping with crisp, well controlled turns under normal operating conditions Level 7 to 9 gives the tightest course keeping and greatest rudder activity (and power consumption). This can lead to a rough passage in open waters as the SPX-5 Wheel system may 'fight' the sea.

Turn rate limit

This limits your boat's rate of turn under SPX-5 Wheel system control.

Screen Text	Range
TURN RATE	1° to 30° per second in 1° steps

Off course angle

This screen determines the angle used by the **OFF COURSE** alarm (see your *Operating Guide*). The **OFF COURSE** alarm operates if the pilot strays off course by more than the specified angle for more than 20 seconds.

Screen Text	Range
OFF COURSE	15° to 40° in 1° steps

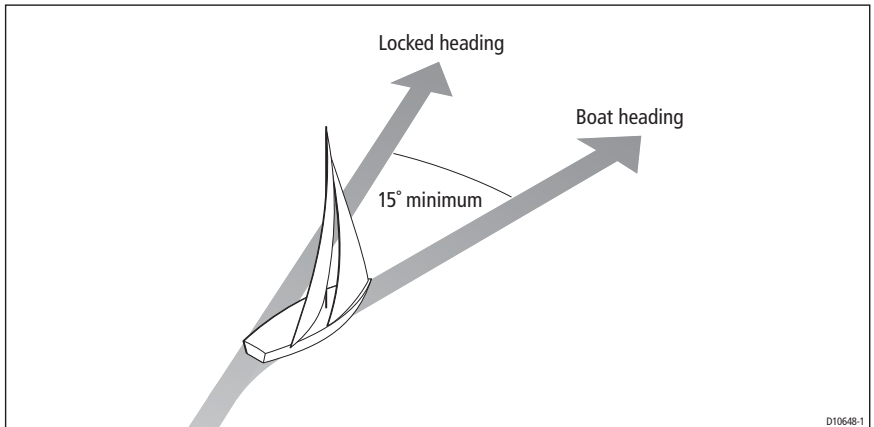

AutoTack

The AutoTack angle is not adjustable. The apparent wind angle when AutoTack is initiated, is mirrored the other side of the wind, on the opposite tack.

See *User calibration*, page 50.

Gybe inhibit

See *User calibration*, page 50.

Wind selection

Note: *Only available if appropriate wind data is available.*

This screen determines whether the boat steers to apparent or true wind in Wind Vane mode. See *User calibration*, page 50.

WindTrim

WindTrim controls how quickly the SPX-5 Wheel system responds to changes in the wind direction. Higher wind trim settings will result in a system that is more responsive to wind changes. See *User calibration*, page 50.

PowerSteer

If you have a joystick connected to your SPX-5 Wheel system, use this screen to select the required joystick mode of operation. For detailed operating information, refer to the guide supplied with the joystick.

Options	
OFF	Joystick off
1	1 = Proportional power steer Proportional power steer applies rudder in proportion to joystick movement – the further the joystick is held over, the greater the applied rudder.
2	2 = Bang-bang power steer Bang-bang power steer applies continuous rudder in the direction of the lever movement – to improve control, the speed of rudder movement changes with the angle of the lever. For maximum speed, push the lever hardover. If you return the lever to the center position, the rudder will remain in its current position.

Cruise speed

Set the cruise speed to the boat's typical cruising speed. If neither the speed through the water nor the speed over ground are available via SeaTalk or NMEA, the SPX-5 Wheel system will use the cruise speed value you set here as a default when calculating course changes.

Screen Text	Range
CRUISE SP	4 to 60 knots

Latitude

If valid latitude data is available via SeaTalk or NMEA, the SPX-5 Wheel system will use this data instead of the calibration value.

Screen Text	Range
LATITUDE	0° to 80° in 1° steps

System reset

CAUTION: Losing settings at system reset

Do NOT carry out a System RESET unless advised to do so by a Raymarine dealer. If you complete a reset you will lose the SPX-5 Wheel system calibration settings. You will then need to repeat the SPX-5 Wheel system commissioning process.

Carrying out a System reset will reset User calibration, Seatrial calibration and Dealer calibration settings to their default values.

Note: *the Display calibration settings will not change, as these are stored in each individual controller*

To carry out a system reset:

1. Select the System reset (**RESET**) screen in Dealer calibration.
2. Press +1 then press auto.
3. The screen will then show an **ARE YOU SURE** message. Either:
 - Press auto to cancel the reset
 - or
 - Press +1 again to select **YES** and reset the SPX-5 Wheel system.
4. You will then see the **CAL LOCK** screen:
 - Hold down standby for 2 seconds to save the new settings, then turn the SPX-5 Wheel system computer power off and back on.

If you reset the system parameters, you must carry out the SPX-5 Wheel system commissioning process before using the SPX-5 Wheel system again.

4.5 System defaults

Parameter	Defaults
Calibration Lock	OFF
Vessel Type	SAIL BOAT
Drive Type	3
Rudder Alignment	0
Rudder Limit	30
Rudder Gain	2
Counter Rudder	2
Rudder Damping	2
AutoTrim	1
Response:	5

Parameter	Defaults
Turn Rate Limit	7
Off Course Angle	20
AutoTack Angle	Relative
Gybe Inhibit	ON
Wind Type	APP
Wind Trim	5
Power Steer (Joystick)	OFF
Cruise Speed	8
Latitude	0
Autopilot Reset	OFF

Appendix 1: NMEA 0183 sentences

The SPX-5 Wheel Course Computer supports the following NMEA0183 sentences.

NMEA0183 to Course Computer

Header	Data in
APB	Cross track error, bearing to waypoint, waypoint number
BWC BWR	Bearing to waypoint, distance to waypoint, waypoint number, time
GGA GLL	Latitude/longitude, time
HDG HDM HDT	Heading
MWV	Apparent wind angle, apparent wind speed
RMA	Course over ground (COG), speed over ground (SOG), latitude/longitude, variation
RMB	Cross track error, bearing to waypoint, distance to waypoint, waypoint number
RMC	Course over ground (COG), speed over ground (SOG), latitude/longitude, time, variation
VHW	Speed through water, heading
VTG	Course over ground (COG), speed over ground (SOG)
VWR	Apparent wind angle (AWA) and apparent wind speed (AWS)
XTE	Cross track error
ZDA	Time, date

NMEA0183 from Course Computer

Header	Data out
HDG	Heading
HDT	True heading (requires true heading data to be available.)
RSA	Rudder angle. Available only if Rudder Reference option is fitted.

* The computer will only transmit these items if it has received the appropriate data.

Appendix 2: SPX-5 Wheel system specifications

Course Computer

Nominal supply voltage	12 V dc (10 A fuse protection at distribution panel) (10 A thermal circuit breaker protection at distribution panel)
Operating voltage range	10 V to 16 V dc
Current consumption (standby)	200 mA
Gyro	Built in
Environmental conditions:	
• operating temperature	-10°C to 55°C (14°F to 131°F)
• non-operating temperature	-20°C to 70°C (-4°F to 158°F)
• relative humidity limit	80%
• water protection	Drip resistant when mounted vertically
Storage conditions when packed:	
• temperature range	-5°C to 50°C (23°F to 122°F)
• relative humidity limit	75%
Dimensions:	Width: 240 mm (9 ⁷ / ₁₆ "), Height: 170 mm (6 ¹¹ / ₁₆ "), Depth: 55 mm (2 ³ / ₁₆ ")
Weight	600 g (1 lb 5.2oz)
Inputs	Fluxgate Compass, NMEA 0183 v3.01, SeaTalk (x2), SeaTalk ^{ng} and power
Outputs	NMEA 0183 v3.01, SeaTalk (x2), drive motor and SeaTalk ^{ng}
Raymarine drive compatibility:	ST4000 Wheel Drive (as supplied with product) ST4000 Tiller Drive (standard and GP)
Drive motor output:	Continuous 5 A at nominal 12 V
SeaTalk output:	2A at 12 V (fuse protected at 2A)
NMEA 0183 v3.01 inputs/outputs	See <i>Appendix 1: NMEA 0183 sentences</i>
Fast heading output	NMEA 0183 - 5 Hz SeaTalk ^{ng} - 10 Hz NMEA 2000 - 10 Hz
Fuses	Standard automotive blade fuses to protect: Power Terminals - 15 A SeaTalk Terminals - 2 A
EMC compliance:	Europe 2004/108/EC (EMC) Australia and New Zealand: C-Tick, Compliance Level 2

Wheel Drive

Wheel Drive unit technical specification	
Nominal supply voltage	12 V dc
Operating voltage range	10 V to 16 V dc
Motor Speed	No Load: 6.5 - 11 RPM Hard over speed: 2.5 turns: 15.75 Seconds Max 4 turns: 25.25 seconds max
Torque:	
• Manual override torque:	Max 4Nm
• Continuous torque at helm:	Max 6 Nm (14 V supply, 8.75 RPM)
• Peak torque at helm:	18 Nm
• Power off torque:	Min 20Nm at clutch (to withstand back-driving)
Environmental conditions:	
• operating temperature	-10°C to 55°C (14°F to 131°F)
• non-operating temperature	-20°C to 70°C (-4°F to 158°F)
• water protection	To IPX6 standard
Storage conditions when packed:	-20°C to 50°C (-4°F to 122°F)
temperature range	75%
relative humidity limit	
Inputs	Drive power from compatible Course Computer.
Servicing	Raymarine approved service at 1000 hrs intervals
EMC compliance:	Europe 2004/108/EC (EMC) Australia and New Zealand: C-Tick, Compliance Level 2
Helm tested to:	EN29775 Section 7.2.2 Helm assembly tests. BSEN28848 Helm impact test.

Pilot Controller (ST6002)

Nominal supply voltage:	12 V DC via SeaTalk
Operating voltage range:	10 V to 15 V DC
Current consumption (in Standby mode)	60 mA (less than 200 mA with full lighting)
Operating temperature:	0 °C to +70 °C (32 °F to 158 °F)
Water protection:	waterproof to CFR46
Overall dimensions:	
width	110 mm (4.33 in)
height	115 mm (4.53 in)
depth	41 mm (1.62 in)
Keypad:	8 button illuminated keypad
Liquid Crystal Display (LCD):	shows heading, locked course and navigational data, and up to 15 data pages
LCD illumination:	3 brightness levels + off
Input connections:	SeaTalk (x2) and NMEA 0183
Output connections:	SeaTalk (x2)
EMC compliance:	Europe 2004/108/EC (EMC) Australia and New Zealand: C-Tick, Compliance Level 2

Index

- A
 - Accessing calibration modes, 46
 - AutoLearn, 38
 - AutoTack, 55
 - AutoTrim, 43, 54
- C
 - Calibration modes, 45
 - Certified installation, 1
 - Checking system operation, 41
 - Commissioning
 - Dockside, 31
 - align rudder indicator, 34
 - checking connections, 32
 - checking pilot operating sense, 32
 - set drive type, 34
 - set rudder limits, 34
 - set vessel type, 34
 - switching on, 31
 - requirement, 30, 31
 - Seatrial, 35
 - AutoLearn, 38
 - conditions, 35
 - heading alignment, 37
 - swinging the compass, 35
 - Connecting Wheel Drive, 19
 - Counter rudder, 43, 53
 - Course Computer
 - connections, 11
 - Fluxgate Compass, 23
 - NMEA0183, 29
 - Pilot Controller, 24
 - power, 21
 - rudder reference, 27
 - SeaTalkng, 28
 - Wheel Drive, 21
 - mounting, 9
- D
 - Data pages
 - available functions, 48
 - setup, 47
 - Dealer calibration
 - align rudder indicator, 53
 - AutoTack, 55
 - AutoTrim, 54
 - counter rudder, 53
 - cruise speed, 56
 - drive type, 53
 - latitude, 56
 - off course warning angle, 55
 - power steer, 56
 - response level, 54
 - rudder damping, 54
 - rudder gain, 53
 - rudder limit, 53
 - seatrial calibration lock, 52
 - system reset, 57
 - turn rate limit, 55
 - vessel type, 52
 - wind type, 56
 - WindTrim, 56
 - Default settings, 57
 - Display calibration, 47
 - data page setup, 47
 - heading selection, 47
 - Drive type, 53
 - setup, 34
- E
 - EMC information, v, 7
- F
 - Fluxgate Compass
 - connecting, 23
 - locating, 22
 - mounting, 23
 - Fuse, 21
- G
 - Grounding, 26
 - Gybe inhibit, 50
- H
 - Heading alignment, 37
 - Heading selection, 47
- J
 - Joystick setup, 56
- L
 - Latitude, 56
- M
 - Magnetic/true heading selection, 47
 - Manual setup
 - AutoTrim, 43
 - checking operation, 41
 - counter rudder, 43
 - response level, 41
- N
 - NMEA0183
 - connections, 29
 - inputs, 59
 - outputs, 59

- O
- Off course warning angle, 55
- P
- Parts supplied, 4
- Pilot Controller
 - connecting, 24
 - SeaTalk power NOT supplied by Course Computer, 25
 - SeaTalk power supplied by Course Computer, 24
 - fitting, 24
- Power cable requirement, 8
- Power connection, 21
- Power steer (joystick) mode, 56
- Power supply protection, 21
- Product disposal, vi
- R
- Resetting the system, 57
- Response level, 50, 54
 - temporary changes, 41
- Rudder damping, 54
- Rudder gain, 53
 - setup, 42
- Rudder indicator alignment, 53
 - setup, 34
- Rudder limits, 53
 - setup, 34
- Rudder reference option, 27
- S
- Safety
 - electrical, v
 - general, v
 - navigation, v
- SeaTalkng connections, 28
- Seatrial Calibration, 35
 - AutoLearn, 38
 - conditions, 35
 - heading alignment, 37
 - swinging the compass, 35
- Seatrial calibration lock, 52
- Setup
 - accessing calibration modes, 46
 - AutoTrim, 43, 54
 - counter rudder, 43, 53
 - cruise speed, 56
 - data pages, 47
 - drive type, 34, 53
 - for joystick operation, 56
 - gybe inhibit, 50
 - heading selection, 47
 - latitude, 56
 - off course warning angle, 55
 - power steer (joystick) mode, 56
 - response level, 50, 54
 - rudder damping, 54
 - rudder gain, 42, 53
 - rudder indicator alignment, 34, 53
 - rudder limit, 53
 - rudder limits, 34
 - seatrial calibration lock, 52
 - turn rate limit, 55
 - vessel type, 34, 52
 - wind type, 50, 56
 - WindTrim, 50, 56
- ST6002 Pilot Controller
 - connecting, 24
 - SeaTalk power NOT supplied by Course Computer, 25
 - SeaTalk power supplied by Course Computer, 24
 - fitting, 24
- Swinging the compass, 35
- Switching on, 31
- System defaults, 57
- System grounding, 26
- System reset, 57
- T
- Tools required, 5
- Turn rate limit, 55
- U
- User calibration, 49
 - gybe inhibit, 50
 - response level, 50
 - wind type, 50
 - WindTrim, 50
- V
- Vessel type, 52
- Vessel type setup, 34
- W
- Wheel Drive
 - cable routing, 20
 - connecting, 19
 - mounting, 11
 - attaching pedestal bracket, 15
 - drilling spoke clamp holes, 12
 - securing wheel drive to wheel, 14
- Wind type, 50, 56
- WindTrim, 50, 56

Wheel drive - spoke clamp template

